

N NARGESA®

NON-MANDREL TUBE AND PIPE BENDER

CC90 CNC



 4.0 Technology



+ than 40 years
manufacturing industrial machinery

TUBE AND PIPE BENDER

The new generation of CC60 non-mandrel machines can bend up to 180° curves on hollow profiles ensuring the best bent finishes in today's market. Equipped with a Touch Screen control grant the user interaction with the standard features offered using the latest 4.0 technology. The sleek look, versatility and faster bending speeds also allows us to have one of best machines offered in our industry. Materials can be round, oval, square, rectangular and made of different metals such as steel, aluminium, stainless steel, copper...

GET A QUOTE

Please complete the following form. We'll contact you in less than 24 hours.

Business days

HOW IT WORKS VIDEO

Video on how the machine works

Follow us on

CC60

Maximum working stroke: 60mm o 2" Schedule-40 o 2" 1/4 x 4mm.

Maximum radius of curvature: 320 mm or 12,60".

CNC control with 7" touch-screen included.

4.0 Technology.

Automatic rotation speed from 0.7 up 4.5 rpm.

Automatic unlocking.

Automatic and programmable springback.

Offset head for complex parts.

Reinforcement tool post support included.

Packaging included.



CC90

Maximum working stroke: 90mm o 3" Schedule-40 o 3" 1/2 x 6mm.

Maximum radius of curvature: 346 mm or 13,60".

CNC control with 7" touch-screen included.

4.0 Technology.

Automatic rotation speed from 1.5 up 5.4 rpm.

Automatic unlocking.

Automatic and programmable springback.

Offset head for complex parts.

Reinforcement strap included.

Packaging included.



TECHNICAL SPECIFICATIONS

Motor power: 4 KW / 5,5 HP.

Electrical voltage: 230/400V Three phase 50/60Hz.

Intensity: 16/9 A.

Machine weight: 900Kg / 1985 lbs.

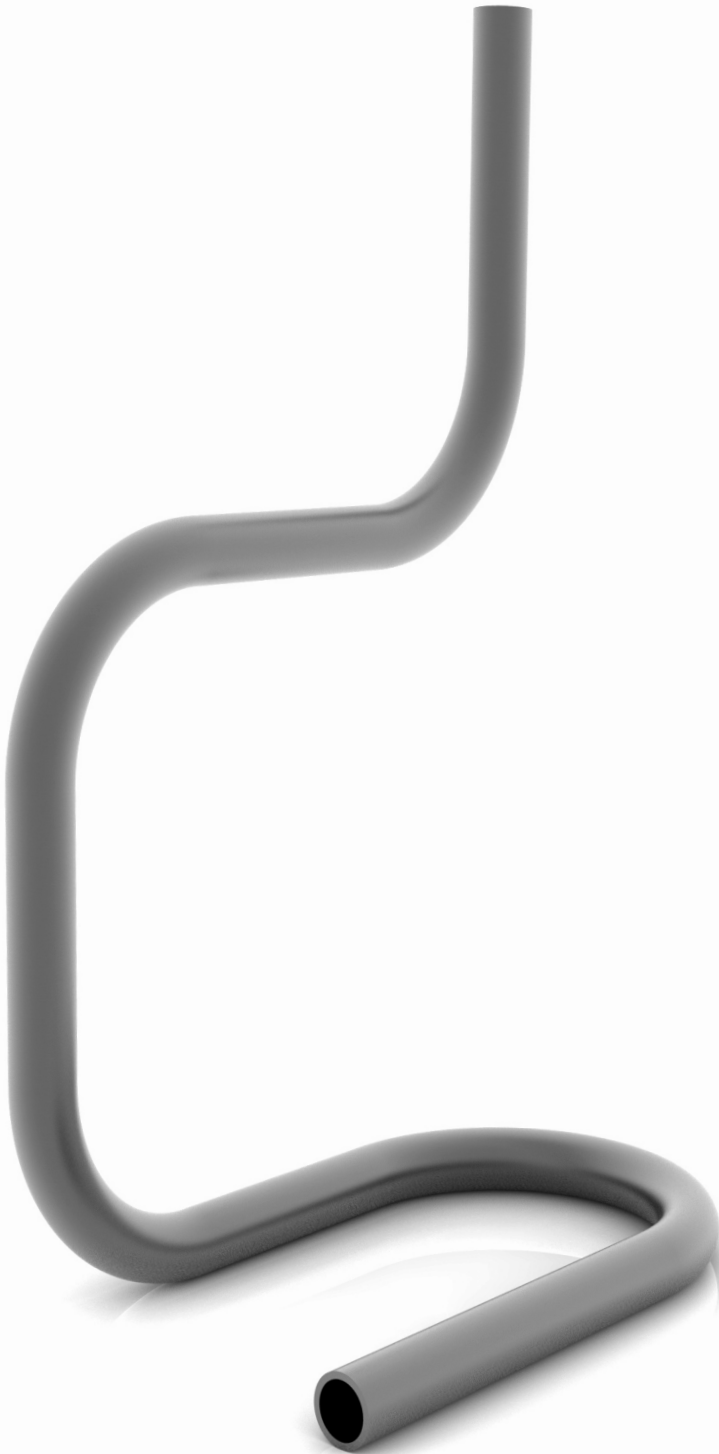

- > **Maximum size on S275 round steel pipe**
90mm o 3" Schedule-40 o 3" 1/2 x 6mm.
- > **Maximum size on aluminium pipe**
90mm x 10 mm / 3" 1/2 x .393".
- > **Maximum size on stainless steel pipe 304 / 316**
90mm x 4mm / 3" 1/2 x .157".
- > **Maximum size on square tube**
60x60x4mm / 2.36" x 2.36" x .160".
- > Maximum angle of curvature: 180°
- > Minimum radius of curvature: 3 times the pipe diameter.
- > Maximum radius of curvature: 346mm.
- > Repetition on the curve of +/- 0.1 degrees.
- > Reinforcement tool post support arm for pipes with diameters over 40 mm included.
- > 400 ml BEND 8 lubricant included.
- > Two bending directions, right or left for easier bending.
- > Quick die change over: Maximum 60 seconds.
- > CNC control with 7" touch-screen with more than 20 different languages.
- > Safety pedal to the right and left.
- > Side shelving to store tools.
- > All bend dies are made of tempered steel for longer tool life.
- > The counter dies are made of bronze alloys to help prevent markings on the outside of the bent profiles.
- > Stores up to 10,000 programs.
- > Up to 50 different angles on the same piece can be programmed.
- > Dimensions can be programmed in inches or millimetres.
- > Pivot system with automatic unlocking to help remove material.
- > Automatic and programmable spring back correction.

** All our products are made at our facilities in Spain. The hydraulic and electronic components are completely standard and from the best leading European brands with technical assistance services throughout the world: Rexroth, Bosch, Roquet, Schneider Electric, LG, Telemecanique, Pizzato...*



WHAT YOU SHOULD KNOW BEFORE PURCHASING A PIPE BENDER

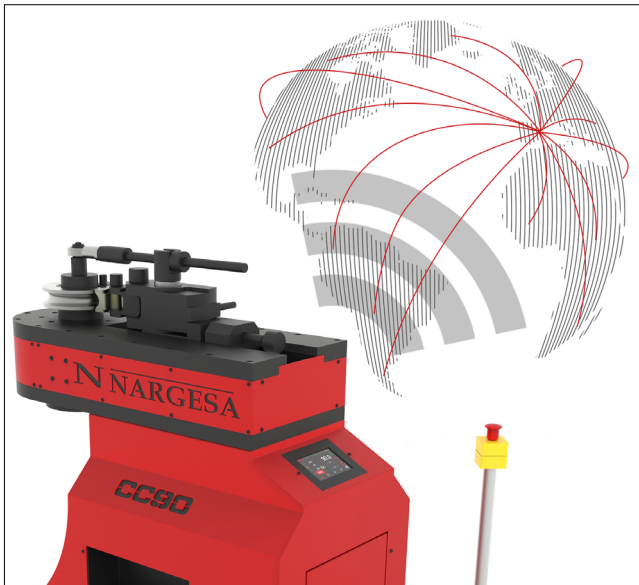

4.0 Technology

The advantages of having this technology in a machine are endless, so we're only going to mention the most relevant. Whenever a customer agrees, the manufacturer may remotely connect to their machine to do any software updates completely free of cost and detect any anomalies in the machine without needing to travel to the machine site. Customers are notified when preventive maintenance must be done on the machine along with many other advantageous features.

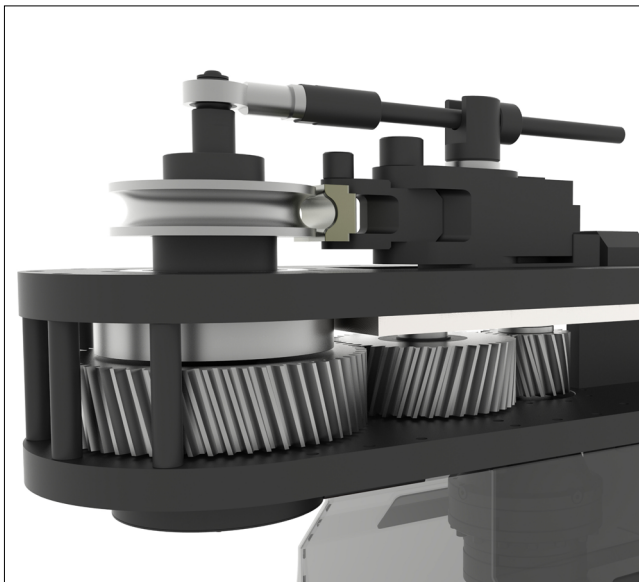

Robustness and speed

The weight of the machine in comparison to other brands provides an idea of how it's built. Some of our units are almost double in weight than our competitors. These are not DIY machines; they're pipe benders that can work 24 hours a day. Made of robust materials, which are tempered in areas subject to wear, and activated with a helical-cut pinion planetary gear system. The rotation speed is also something to be taken into account. It can reach 4.5 rpm for more aggressive production; in many cases, more than twice as much when compared to similar machines in today's market.



Curve thicknesses and finishes

Most tube and pipe benders can only bend very thick-walled pipes with a 10% minimum thickness of the diameter of the pipe normally calculated. For example, a good curve on a 40 mm pipe is usually guaranteed with a 3.5 or 4 mm wall thickness. The original counter-shape designed by Nargesa guarantee a good finish even with a thin-walled pipe. The minimum thickness for a 40 mm pipe can be 1.5 or 2 mm. This significantly lowers the cost of the raw material.



Offset head and two-directional bending

The offset head design allows for complex curves as the pipe goes underneath the head. Bending pipe below the head is not possible with some pipe bender models. The all-new CC60 and CC90 benders can curve to the right and left without needing to rotate the die, meaning any piece can be bent regardless its complexity.

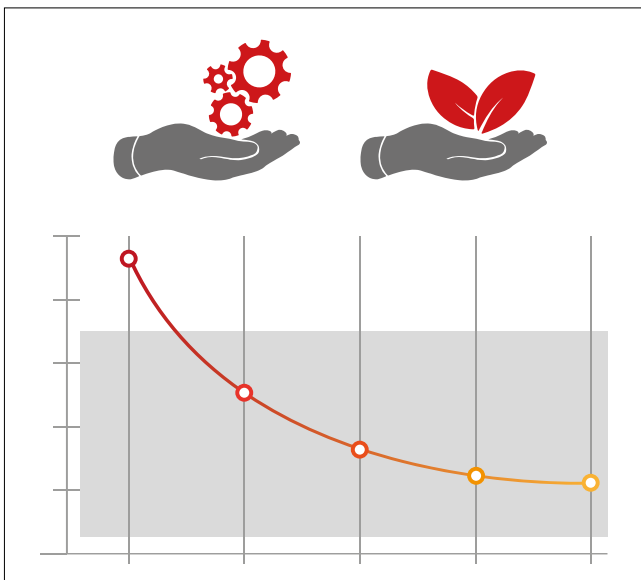

Enhanced energy efficiency

The consumption per machine working stroke has been significantly reduced to save energy. Only 4 Kw with a working stroke of up to 88.9 mm.



Automatic unlocking

The bending carriage moves automatically to the right or to the left depending on the direction of the curve to more easily release the piece without needing to re-adjust the grip. This original system can complete pieces in much less time.



Reinforcement tool post support included

The CC90 CNC pipe bender comes standard with a reinforcement arm. It's used to prevent machine chassis deformations. The Control indicates when this device is required or not required.



Bend 8 Lubricant included

With the purchase of the CC90 CNC pipe bender, you'll receive a 400 ml bottle of special bending lubricant: for a better finish on the outside of the curve, to prevent roughness and inner corrugation and reduce wear on the counter-shape die. Ideal for thin tubes and pipes. Lubricates to reduce friction. Prevents and dissolves corrosion. Polishes and protects. Cleans and removes dirt.



ESA S625 CONTROL PANEL

Nargesa tube and pipes benders are controlled with a very intuitive and easy-to-use 7" colour touch-screen with the latest 4.0 technology. Just enter the pipe dimensions, thickness, angle of the curve or curves and choose a die from the library and the control programs the rest of the parameters automatically; elastic recovery correction or springback, recommended rotation speed, whether a tool post support is necessary or not, and if the intended curve is possible... All of this may be modified by the end user based on their own needs. These are some of the most relevant features of this control system.

- > Stores up to 10,000 programs.
- > Up to 50 different angles on the same piece can be programmed.
- > Dimensions may be programmed in inches or millimetres.
- > A library of available dies with the possibility of programming new ones.
- > A library of differently shaped pipes with varying thicknesses.
- > The CNC can be supplied in more than 20 different languages.
- > Automatic or manual rotation speed adjustment from 1.5 to 5.4 rpm.
- > Manual or automatic operation.
- > Automatic elastic recovery correction (springback).
- > Piece counter.
- > Independent correction of the programmable final curve degree.
- > 4.0 Technology.
- > On-screen alarm diagnostics.
- > Preventive maintenance warning.
- > Can be remotely connected by the manufacturer without having to travel to the machine site.
- > Warning on screen if the tool post support needs to be used.
- > 7" colour touch-screen with 800 x 480 resolution.
- > 128 MB silicon disk.
- > 2 analogue inputs, 12 bit resolution.
- > 16 digital inputs (24 Vdc).
- > 16 digital outputs (24 Vcc, 0.7 A max.) Protected against overloads and short circuits.
- > 1 RS232 serial port.
- > 1 CAN port with 9 D-Sub F connector contacts.
- > 24 Vdc power source.
- > 1 USB port.

OUTSIDE DIMENSIONS

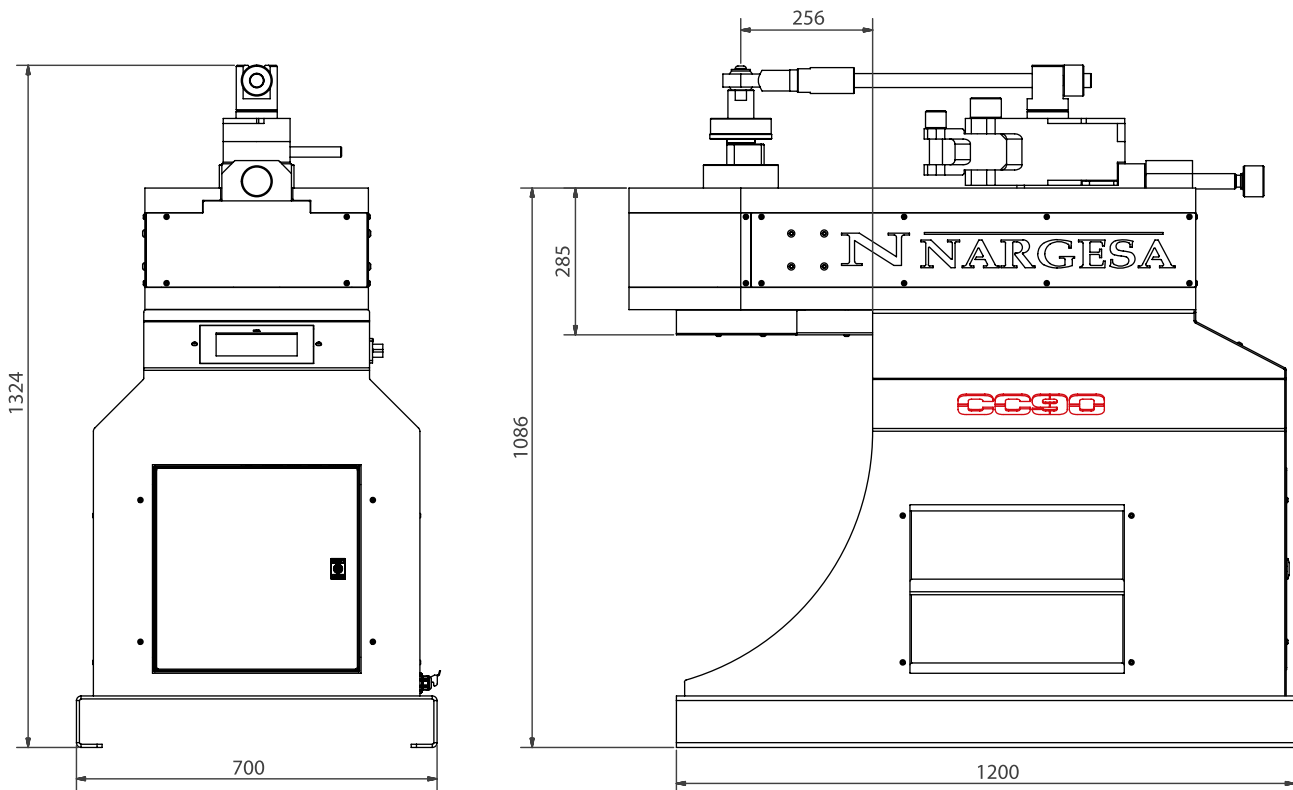

PACKAGING CHARACTERISTICS

Tariff Code: 84622180

- A lower pallet bench to transport the machine to the work site or storage.
- The CC90 pipe bender is sent completely assembled.
- An wooden pallet and 3-layer cardboard box suitable for seafreight.
- Optional: NIMF15 wooden container.

CC90 CNC

Width	830 mm
Depth	1290 mm
Height	1524 mm
Volume	1,63 m ³
Net Weight	900 Kg
Gross Weight	935 Kg

ACCESSORIES

Accessories supplied with the Pipe Bender

BEND8 aerosol lubricant



The CC90 pipe bender comes with a 400 ml bottle of BEND8 lubricant.

Formats available for this product:

REF. 060-SPR-00003 400 ml bottle.

REF. 060-SPR-00004 Box of 12 400 ml bottles.

This is a high-additive and low-viscosity aerosol oil. Contains PTFE.
Does not contain silicone.

- > Enables the finish on the outer bend.
- > Inhibits roughness and inner marks.
- > Reduces wear of the tooling.
- > Especially designed for tubes of small thickness.
- > Lubricates to reduce friction.
- > Avoids and dissolves corrosion.
- > Gives shine and protects.
- > Cleans up and removes dirt.

OPTIONAL ACCESSORIES

Customers must equip their pipe bender with a specific die to get the desired curving.

The diameter and thickness of the pipe as well as the radius of curvature must be taken into account when choosing a roller.

Characteristics of the elements:

Main Roller made of highly resistant steel which has been thermally hardened with carbonitriding for 50-54 HRC hardness; this roller guide perfectly adapts to the pipe for excellent results.

Counter-shape designed by the Nargesa R+D department which reduces friction and ensures optimal curving. It's made of a highly resistant aluminium bronze alloy and mechanized in 3D.

Clamp with a fastener to firmly secure the material during the bending process.

Support holder made of highly resistant steel which has been thermally treated with carbonitriding for 50-54 HRC hardness; this roller reduces the surface of contact with the counter-shape and, therefore, reduces friction.

Accessories for round pipes in millimetres · 15 to 90 mm



Rollers made of treated Steel. Units suitable for bending all types of round pipes 15 to 90 millimetres.

The following is supplied with the unit: A main roller, a counter-shape, a clamp with a fastener.

Check with the manufacturer for other dimensions.

Ø Ext.	Radius	Min. thickness	Max. thickness	Weight
Set diameter 15mm Radius 60				REF: 140-17-01-10001
15 mm	4D=60 mm	1 mm	5 mm	3,18 Kg
Set diameter 20mm Radius 60				REF: 140-17-01-10002
20 mm	3D=60 mm	1 mm	5 mm	3,22 Kg
Set diameter 25mm Radius 75				REF: 140-17-01-10003
25 mm	3D=75 mm	1,2 mm	5 mm	5,55 Kg
Set diameter 30mm Radius 90				REF: 140-17-01-10004
30 mm	3D=90 mm	1,2 mm	5 mm	8,29 Kg
Set diameter 35mm Radius 105				REF: 140-17-01-10005
35 mm	3D=105 mm	1,5 mm	5 mm	12,14 Kg
Set diameter 40mm Radius 120				REF: 140-17-01-10006
40 mm	3D=120 mm	1,5 mm	5 mm	17,11 Kg
Set diameter 50mm Radius 150				REF: 140-17-01-10007
50 mm	3D=150 mm	2 mm	5 mm	31,41 Kg
Set diameter 60mm Radius 180				REF: 140-17-01-10008
60 mm	3D=180 mm	2 mm	4 mm	40,88 Kg
Set diameter 70mm Radius 210				REF: 140-17-02-10001
70 mm	3D=210 mm	3,6 mm	6 mm	72,40 Kg
Set diameter 80mm Radius 240				REF: 140-17-02-10002
80 mm	3D=240 mm	4 mm	5 mm	88,17Kg
Set diameter 90mm Radius 270				REF: 140-17-02-10003
90 mm	3D=270 mm	4 mm	5 mm	114,36 Kg

* The walls with more thickness to the established one and the materials with more resistance, reduce the capacities of the machine.

Accessories for round pipes 3/8" to 2" 1/2 Schedule



Rollers made of treated Steel. Units suitable for bending all types of round pipes 3/8" to 2" 1/2 Schedule.

The following is supplied with the unit: A main roller, a counter-shape, a clamp with a fastener.

Check with the manufacturer for other dimensions.

Ø Ext.	Ø Ext.	Radius	SCH10	SCH40	SCH80	SCH120	Weight
Die Set Diameter 17.10mm Radius 60mm Diameter 3/8 "Schedule						REF: 140-17-01-20001	
3/8"	17,1 mm	60 mm	1,65 mm	2,31 mm	3,20 mm	--	4,22 Kg
Die Set Diameter 21.30mm Radius 63.9mm Diameter 1/2 "Schedule						REF: 140-17-01-20002	
1/2"	21,3 mm	3D=63,9 mm	2,11 mm	2,77 mm	3,73 mm	4,78 mm	3,56 Kg
Die Set Diameter 26.70mm Radius 80.1mm Diameter 3/4 "Schedule						REF: 140-17-01-20003	
3/4"	26,7 mm	3D=80,1 mm	2,11 mm	2,87 mm	3,91 mm	5,56 mm	6,74 Kg
Die Set Diameter 33.70mm Radius 101.1mm Diameter 1 "Schedule						REF: 140-17-01-20004	
1"	33,7mm	3D=101,1 mm	2,77 mm	3,38 mm	4,55 mm	6,35 mm	11,18 Kg
Die Set Diameter 42.40mm Radius 127.2mm Diameter 1 "1/4 Schedule						REF: 140-17-01-20005	
1" 1/4	42,4 mm	3D=127,2 mm	2,77 mm	3,56 mm	4,85 mm	6,35 mm	18,86 Kg
Die Set Diameter 48.30mm Radius 144.9mm Diameter 1 "1/2 Schedule						REF: 140-17-01-20006	
1" 1/2	48,3 mm	3D=144,9 mm	2,77 mm	3,68 mm	5,08 mm	--	27,05 Kg
Die Set Diameter 60.30mm Radius 180.9mm Diameter 2 "Schedule						REF:140-17-02-20001	
2"	60,30 mm	3D=180,9 mm	2,77 mm	3,91 mm	5,54 mm	--	45,75 Kg
Die Set Diameter 73mm Radius 219mm Diameter 2 "1/2 Schedule						REF: 140-17-02-20002	
2" 1/2	73,0 mm	3D=219 mm	3,05 mm	5,16 mm	7,01 mm	--	72,00 Kg

Accessories for 3" Schedule round pipes

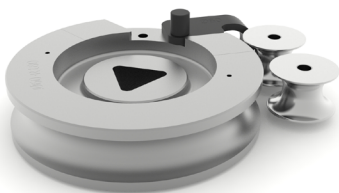

Rollers made of treated steel. Suitable kit to bend 3" Schedule tube of 3,05mm wall thickness or thicker.

The following is supplied with the unit: A main roller, a clamp with a fastener, a support holder.

Check with the manufacturer for other dimensions.

Supporting Roller Kit REF: 140-17-02-00002 is required.

Ø Ext.	Ø Ext.	Radius	SCH10	SCH40	SCH80	SCH120	Weight
Die Set Diameter 88.9mm Radius 266.7mm Diameter 3 "Schedule						REF: 140-17-02-30003	
3"	88,9 mm	3D=266,7 mm	3,05 mm	5,49 mm	--	--	101,80 Kg

* All capacities are based on the norm of carbon steel tubes according to ASTM, Standard A-53 grade A with a maximum resistance strength of 330MPa. The walls with more thickness to the established one and the materials with more resistance, reduce the capacities of the machine. Check with your material supplier for the specifications of this one.

Accessories for round pipes in inches · 5/8" to 3" inches



Rollers made of treated Steel. Units suitable for bending all types of round pipes 5/8" to 3" inches.

The following is supplied with the unit: A main roller, a counter-shape, a clamp with a fastener.

Check with the manufacturer for other dimensions.

Ø Ext.	Ø Ext.	Radius	Min. thickness	Max. thickness	Weight
Set diameter 15,88mm Radius 60mm Diameter 5/8" inches					REF: 140-17-01-30001
5/8"	15,88 mm	60 mm	1 mm	4 mm	3,61 Kg
Set diameter 19,05mm Radius 60mm Diameter 3/4" inches					REF: 140-17-01-30002
3/4"	19,05 mm	60 mm	1 mm	4 mm	2,79 Kg
Set diameter 25,40mm Radius 76,20mm Diameter 1" inches					REF: 140-17-01-30003
1"	25,40 mm	3D=76,2 mm	1,2 mm	5 mm	5,72 Kg
Set diameter 31,75mm Radius 95,25mm Diameter 1" 1/4 inches					REF: 140-17-01-30004
1" 1/4	31,75 mm	3D=95,25 mm	1,5 mm	6 mm	10,21 Kg
Set diameter 38,10mm Radius 114,30mm Diameter 1" 1/2 inches					REF: 140-17-01-30005
1" 1/2	38,10 mm	3D=114,3 mm	1,5 mm	7 mm	15,69 Kg
Set diameter 50,8mm Radius 152,4mm Diameter 2" inches					REF: 140-17-01-30006
2"	50,80 mm	3D=152,4 mm	2 mm	5 mm	32,24 Kg
Set diameter 57,15mm Radius 171,45mm Diameter 2" 1/4 inches					REF: 140-17-01-30007
2" 1/4	57,15 mm	3D=171,45 mm	2 mm	5 mm	36,13 Kg
Set diameter 63,5mm Radius 190,5mm Diameter 2" 1/2 inches					REF: 140-17-02-30001
2" 1/2	63,50 mm	3D=190,5 mm	3 mm	8,64 mm	40,50 Kg
Set diameter 76,2mm Radius 228,6mm Diameter 3" inches					REF: 140-17-02-30002
3"	76,20 mm	3D=228,6 mm	3 mm	7,21 mm	80,68 Kg

Accessories for 3" 1/2 round pipes

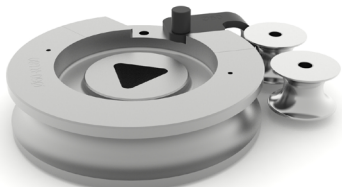

Rollers made of treated Steel. Suitable kit to bend 3" 1/2 tube of 4mm wall thickness or thicker.

The following is supplied with the unit: A main roller, a clamp with a fastener, a support holder.

Check with the manufacturer for other dimensions.

Supporting Roller Kit REF: 140-17-02-00002 is required.

Ø Ext.	Ø Ext.	Radius	Min. thickness	Max. thickness	Weight
Set diameter 88,9mm Radius 266,7mm Diameter 3" 1/2 inches					REF: 140-17-02-30003
3" 1/2	88,9 mm	3D=266,7 mm	4 mm	6,05 mm	110,80 Kg

* The walls with more thickness to the established one and the materials with more resistance, reduce the capacities of the machine.

Supporting Roller Kit CC90

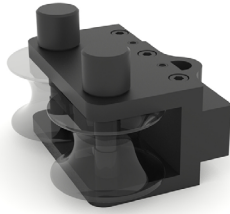

REF: 140-17-02-00002

The CC90 Supporting Roller Kit is used to bend pipes with a diameter equal to or more than 3" Schedule x 3,05mm or 3" 1/2 x 4mm This unit is comprised of:

A roller holder: The roller holder is made up of three highly resistant steel pieces that are precision mechanized and treated on the surface. They're fixed and centred with rectified bolts to ensure proper operation.

The coupling axis: The coupling axis is made up of a chrome Ø20 mm Matera axis.

Weight: 24,573 Kg.

CC90 2-axis positioning gauge

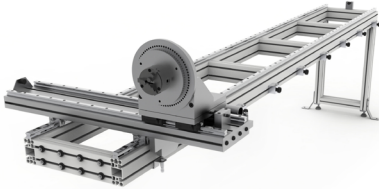

The gauge of the CC90 allows to make mass produced parts, much faster, more accurate and repetitively.

- > Adjustable longitudinal positioning with 6 positions.
- > Angular head rotation every 5 degrees.
- > Four-clamp plate adjustable to round and square tube.
- > Longitudinal movement with high precision linear guides.
- > Automatic anti-collision control.
- > Easy handling and preparation for difficult parts.

REF: 140-17-02-50000

Gauge length: 3000mm.

Maximum capacity: 60,3mm, 2" Schedule.

Weight: 135 Kg.

[VIDEO - Positioning gauge instructions book](#)

OUR RANGE OF MACHINERY



IRON WORKERS



SECTION BENDING
MACHINES



NON-MANDREL PIPE
BENDER



HORIZONTAL PRESS
BRAKES



TWISTING/SCROLL
BENDING MACHINES



HYDRAULIC PRESS
BRAKES



HYDRAULIC SHEAR
MACHINES



GAS FORGES



IRON EMBOSING
MACHINES



END WROUGHT IRON
MACHINES



BROACHING MACHINES



POWER HAMMERS



PRESSES FOR LOCKS

WARRANTY

Nargesa machines have 3 years warranty provided that the customer registers it in our website. Otherwise it would be only one year warranty. This one encloses any manufacturing default all along these 3 years for components. Any misuse is excluded from this condition. Labor, back and forth shipping and any eventual repair, are not included in this warranty.

Partner companies



SHIPMENT EVERYWHERE

Nargesa will arrange transport up to final destination, whenever the customers asks for so. There is also the possibility for the customer to arrange the shipment himself with his own agency.

TECHNICAL ASSISTANCE

All our customers have access to technical support quickly and efficiently.

90% of incidences are solved out on the phone, mail, Skype or videoconferencing in less than 24hours. In case of needing presencial technical assistance, we may as well send a technician to the customer's facilities.

Follow us on

PRADA NARGESA, S.L.

Ctra. De Garrigàs a Sant Miquel s/n
17476 Palau de Santa Eulalia (Girona) Spain
Tel. +34 972 568 085

www.nargesa.com

nargesa@nargesa.com



This information might undergo changes