

DX Series

CNC Turning Centers



DX nvu Series

CNC Turning Centers

OVERVIEW

DX nvu series offers a range of high technology CNC lathe to deliver fastest throughput needed in present competitive market. This range is the result of continuous innovative development Jyoti has made in the field of machine tools, ever since we started manufacturing CNC lathes. The Series is resultant of innovation and customer feedback for performance in the product. With unique features, DX nvu series delivers optimum performance to match demand of various sized workpiece applications.

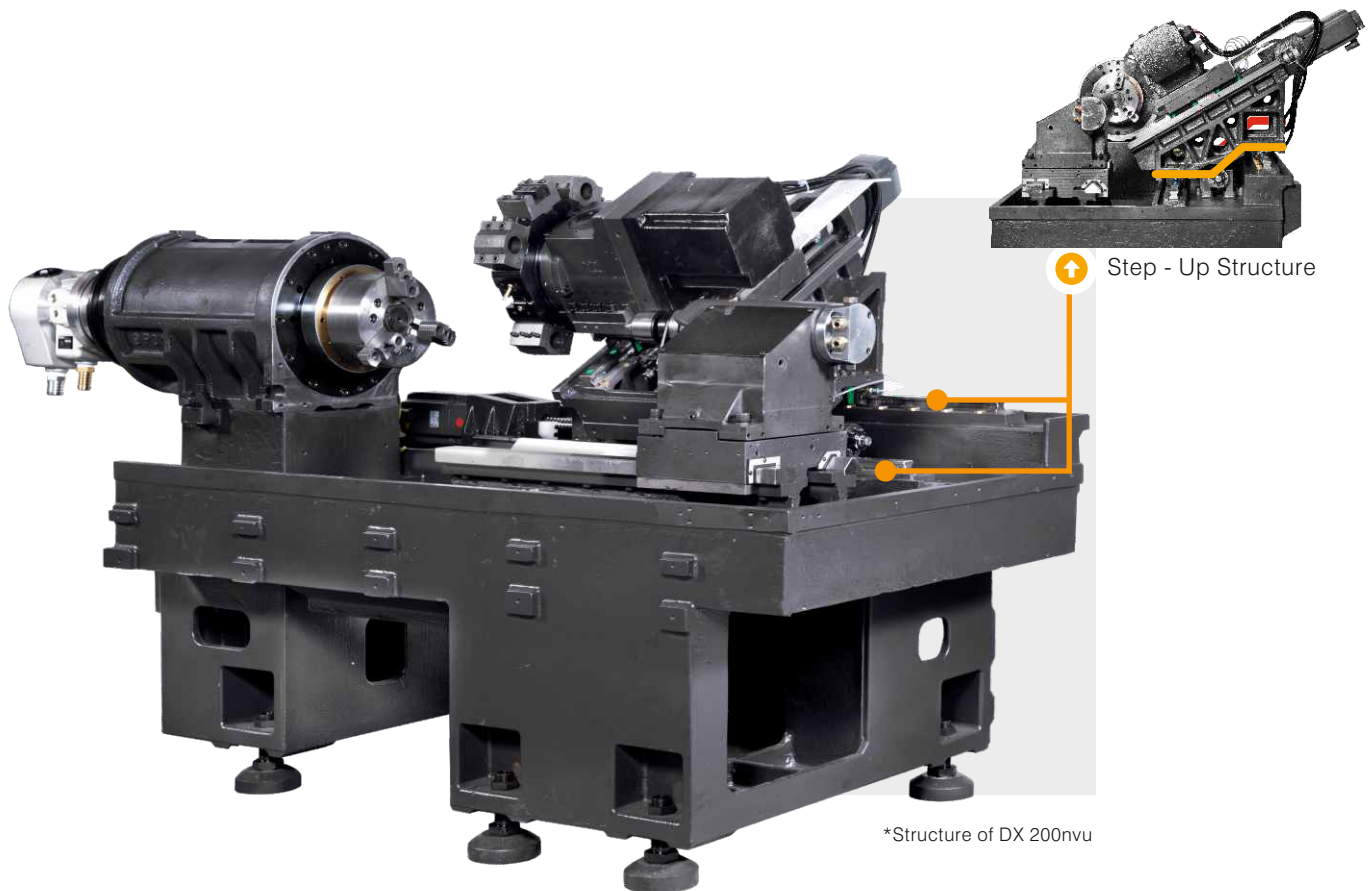

*Structure of DX 200nvu

RIGID STRUCTURE

The rigid bed and single piece 30° slant saddle are made out of high grade cast iron for stability and least distortion enabling heavy depth of cuts and faster production.

Designed to support high acceleration rate as well as high cutting force.

STEP-UP CONCEPT

Step-up structure concept enables vibration free cutting even for larger diameter jobs. With virtually no vibration, it means higher surface finish even on hard materials.



3-POINT LEVELING

Twisting effect of bed can be eliminated due to 3-point leveling
Quick Installation and relocation made easy with this feature.

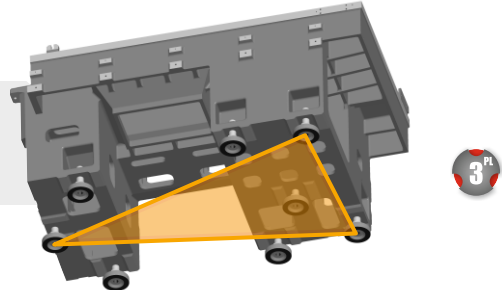

HIGH SPEED SERVO TURRET

DX nvu series machine are equipped with high speed and high precision Bi-directional Servo Turret with hydraulic clamping system achieved by 3-piece hirth coupling.

- Tool Change Time is just 0.5 second which helps to Reduce Cycle Time.
- Upto 20% Higher Productivity
- Less Maintenance & Running Cost
- Increases Tool Life.

TAILSTOCK

A manually movable tailstock with hydraulically actuated quill is a standard feature of the machine. The Tailstocks is supported on V-type & flat guideways. Programmable tailstock with hydraulic movement is offered as an option.

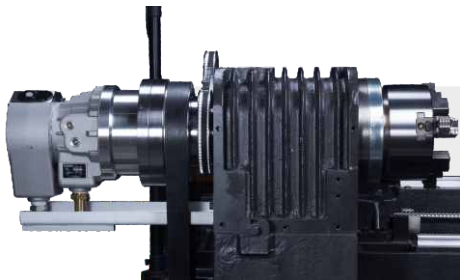

HEADSTOCK & SPINDLE

Headstock is made from closed grain FG 300 casting and provided with fins for better heat dissipation. Machine spindle is manufactured in-house using world class machinery and assembled in a dust free temperature controlled environment. Spindle is housed in a cartridge with super precision angular contact bearings arrangement in front and rear to take care of radial as well as axial loads.

ELECTRO SPINDLE (OPT.)

To make DX 200 nvu precision turning machine, world class electro spindle specially designed & manufactured in-house. High torque availability at low rpm for roughing to finishing operations with high quality surface finishing.

- No Stick Slip because no Belt Mechanism
- Noise free Machining
- Ramp up/Ramp down Time is Very Low.

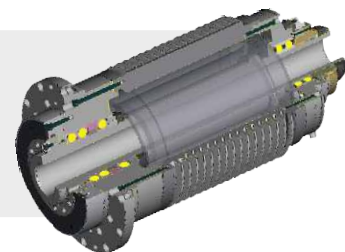

- | | | | |
|-------------------------|------------------|-----------------|----------|
| ▪ Spindle Nose | A ₂ 6 | ▪ Spindle Speed | 4500 rpm |
| ▪ Spindle Power (Cont.) | 9.15 kW | ▪ Base Speed | 500 rpm |

DX nvu Series

CNC Turning Centers

ERGONOMIC DESIGN & TPM CONCEPT

The machine is made considering the reliability, human comfort and operator friendliness

Heavy components can be easily loaded/unloaded from wide front door entry as well as from top of the machine with the help of crane.

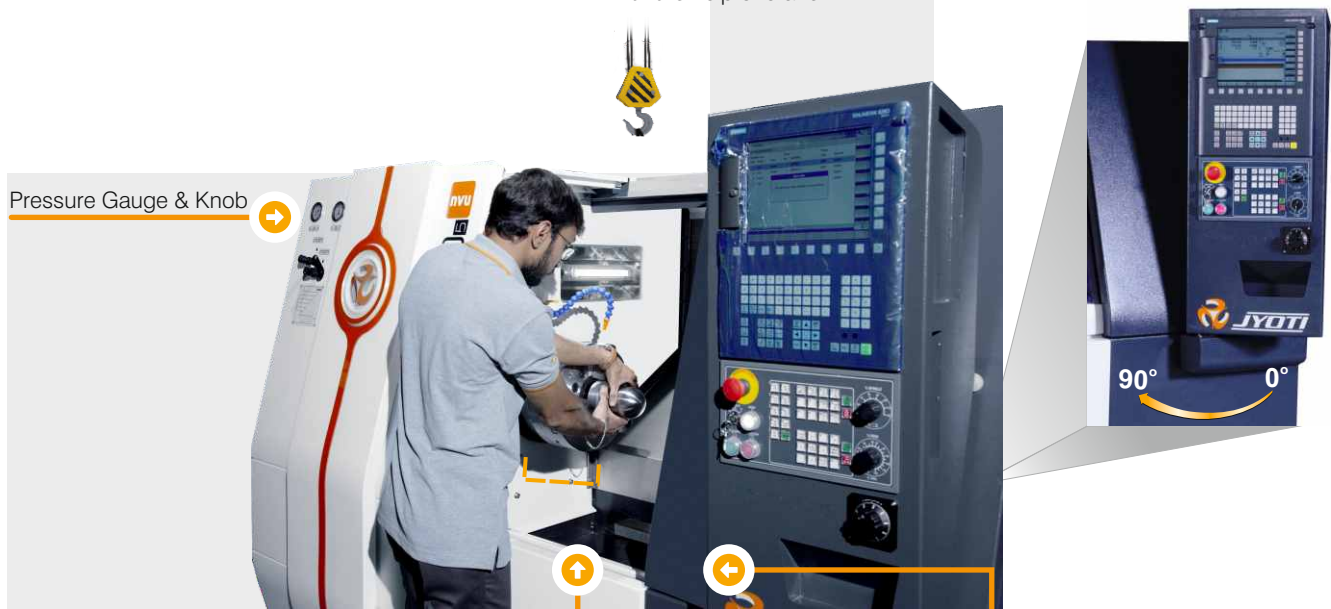

Keeping in mind operator's convenience, approach to spindle is less which make easy loading/unloading of component.

Extra sliding door for easy access and approach for tailstock work

Tailstock Side Window

Lubrication Unit



EASY CHIP EVACUATION

Ergonomically designed concept enables to give efficient rear side chip disposal with coolant. With such design chips will directly fall down into chip tray & removing of chips without disturbing of machining. Rear or side chip conveyor options also available.

PRODUCTIVITY IMPROVING OPTIONS

DX nvu series design concept gives flexibility to user having variety of shafts from small to larger length, combine options of steady rest and programmable tailstock giving better edge for batch type variety productions.

A combination of bar feeder, bar puller & part catcher really improves mass production in long bar applications. Steady rest, Digital tailstock, Live quill, Tool Probe/Job Probe & High Pressure coolant through Turret are other productivity improvement options.





MACHINING RANGE & INTERFERENCE DIAGRAM

DX 135 nvu

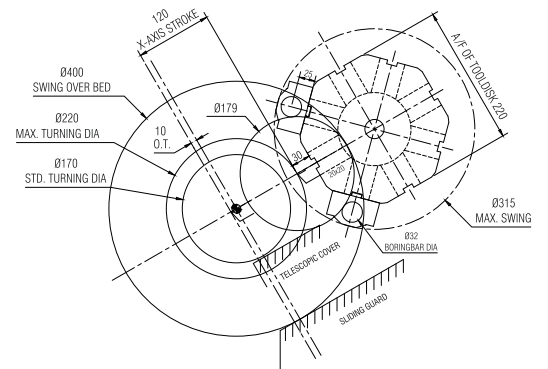
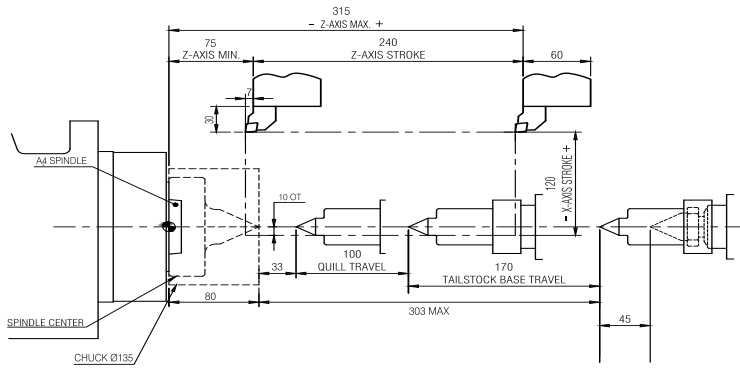

DX 170 nvu

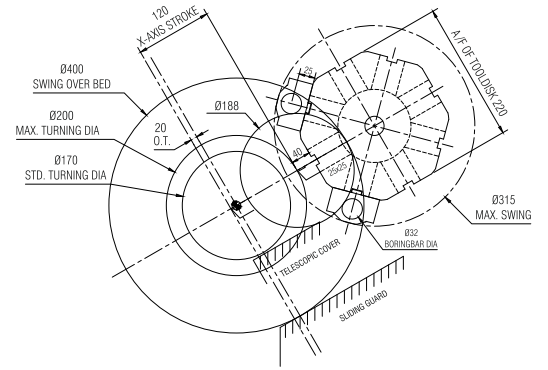
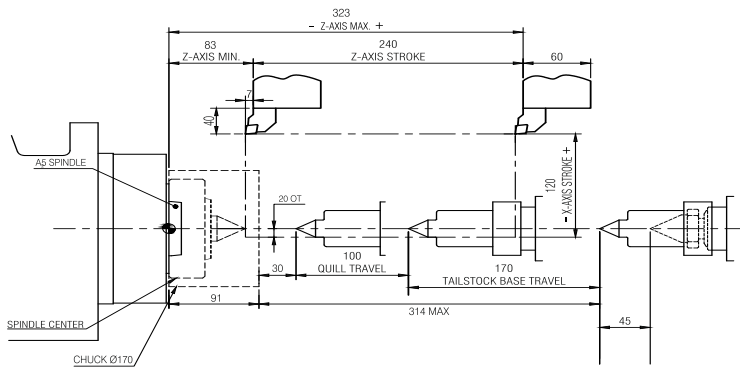

DX 200-5nvu

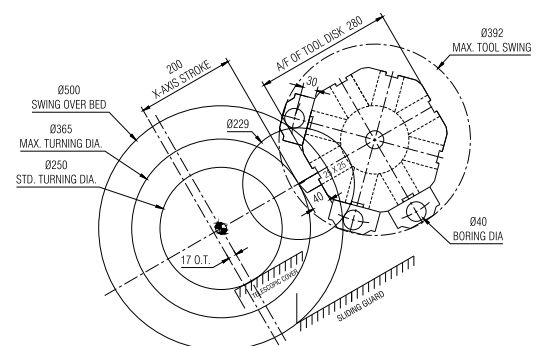
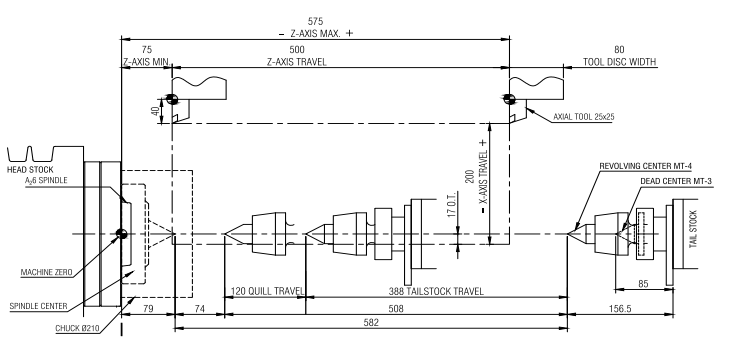

DX 250-500nvu

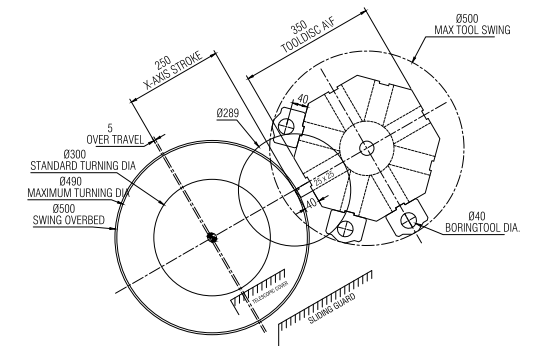
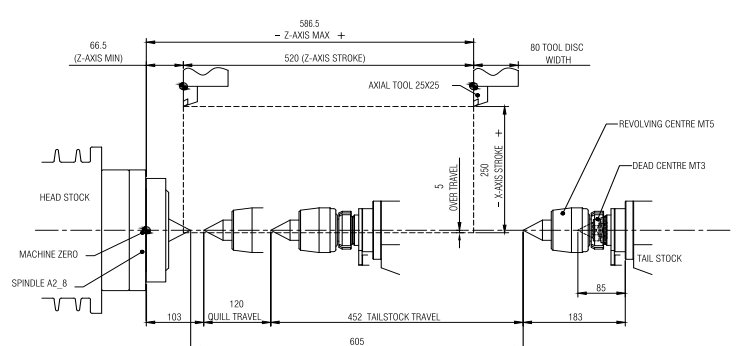

POWER TORQUE DIAGRAM

5.6 / 3.7 kW, 6000 rpm (Siemens)

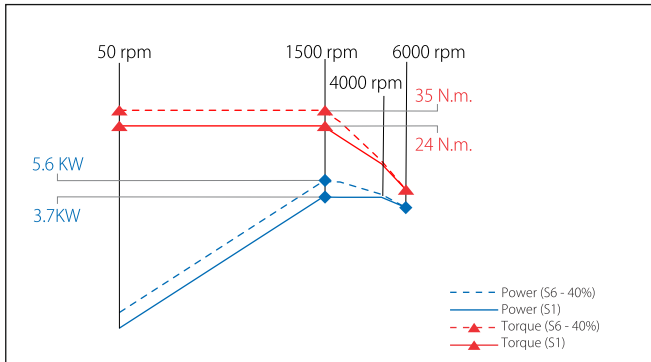

5.5 / 3.7 kW, 6000 rpm (Fanuc)

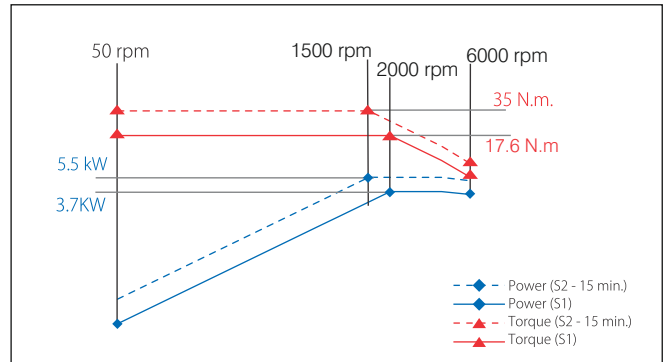

8.3 / 5.5 kW, 4000 rpm (Siemens)

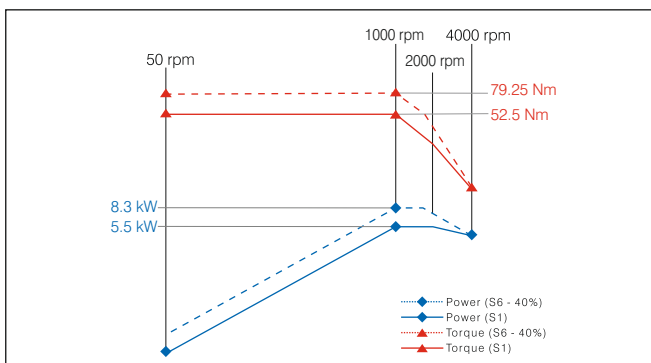

7.5 / 5.5 kW, 4000 rpm (Fanuc)

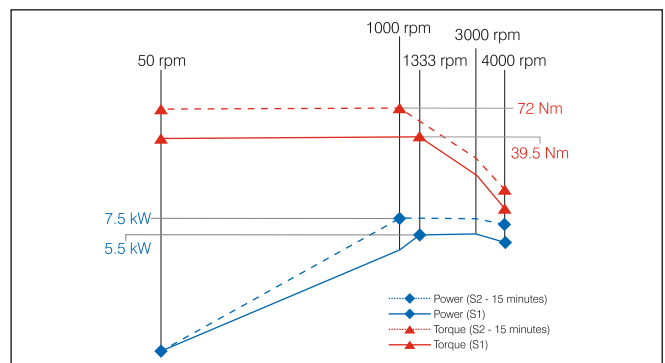

13.5 / 9 kW, 4000 rpm (Siemens)

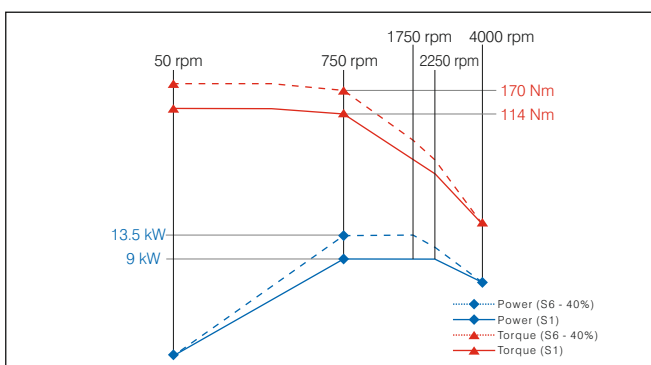

11 / 7.5 kW, 4000 rpm (Fanuc)

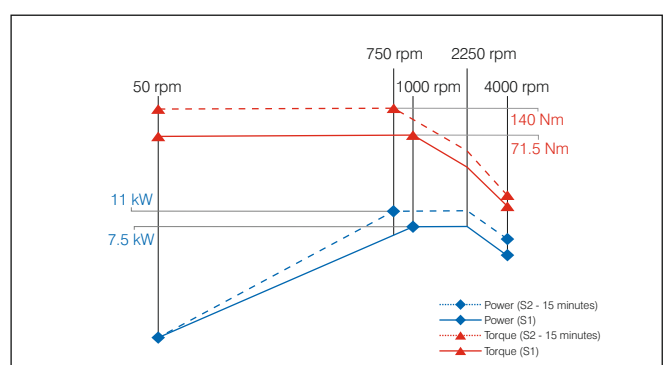

16.5 / 11 kW, 3500 rpm (Siemens)

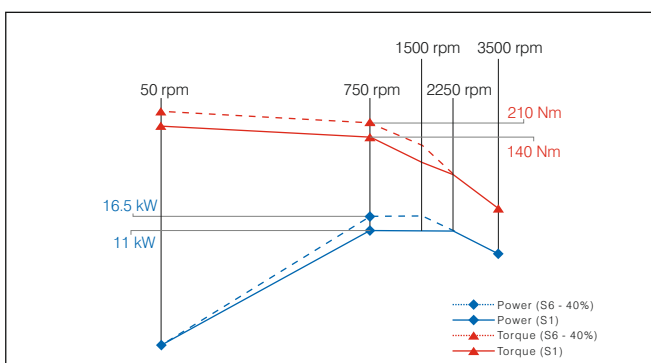

15 / 11 kW, 3500 rpm (Fanuc)

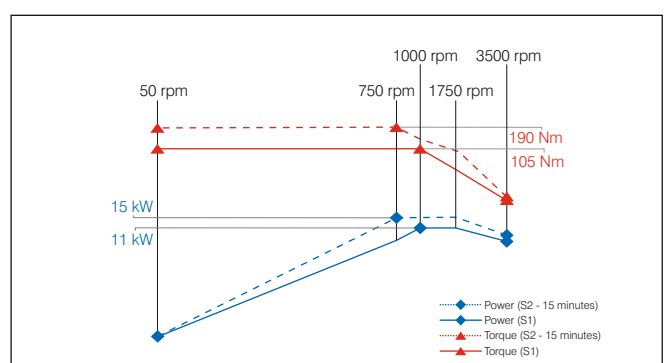



TECHNICAL SPECIFICATION

Capacity		DX 135 nvu	DX 170 nvu	DX 200 - 5A nvu	DX 200 - 5B nvu	DX 250 - 500 nvu
Swing Over Bed	mm	400	400	500	500	500
Std. Turning Dia.	mm	170	170	250	250	300
Max. Turning Dia.*	mm	220	200	365	365	490
Max. Turning Length*	mm	240	240	500	500	500
Slides						
X-Axis Travel (Cross)	mm	120	120	200	200	250
Z-Axis Travel (Longitudinal)	mm	240	240	500	500	520
Rapid Feed (X & Z Axis)	m/min	24	24	24	24	24
Main Spindle						
Spindle Motor Power - Fanuc	kW	5.5 / 3.7	7.5 / 5.5	11 / 7.5	15 / 11	15 / 11
Spindle Motor Power - Siemens	kW	5.6 / 3.7	8.3 / 5.5	13.5 / 9	16.5 / 11	16.5 / 11
Spindle Speed Range	rpm	50-6000	50-4000	50-4000	50-3500	50-3500
Spindle Bore	mm	39	50	70	90	90
Spindle Nose		A ₂ 4	A ₂ 5	A ₂ 6	A ₂ 8	A ₂ 8
Max. Bar Capacity	mm	30	42	52	75	75
Turret						
No. of Station		8	8	8	8	8
Max. Boring Bar Dia.	mm	32	32	40	40	40
Tool Size (Cross Sectional)	mm	20 x 20	25 x 25	25 x 25	25 x 25	25 X 25
Tail Stock						
Quill Dia.	mm	75	75	85	85	85
Quill Stroke	mm	100	100	120	120	120
Thrust	Kgf	300	300	500	500	500
Accuracy (as Per VDI/DGQ 3441)						
Positioning Uncertainty (P)	mm	0.007	0.007	0.007	0.007	0.007
Repeatability (Ps Medium)	mm	0.005	0.005	0.005	0.005	0.005
Other Data :						
Machine Weight # (Approx.)	Kg	2400	2600	3400	3500	4000
Machine Dimension # (Approx.):						
Length	mm	1920	1920	2350	2350	2350
Width	mm	1500	1500	1680	1680	1750
Height	mm	1700	1700	1730	1730	1730

* Depends upon clamping arrangement, Tooling and Job.

Refer Machine Detailed Layout for overall machine dimensions & space requirements.

STANDARD FEATURES

- CNC System offered Fanuc 0i TF or Siemens 828D Basic T
- AC Spindle Drive & Servo Digital Drive
- L. M. Guideways, Roller Type LM Guideways in DX 170 & DX 250-500
- Hydraulic Chucking
- 8 Station Bi-Directional Servo Turret
- Rear Side Chiptray
- Auto & Manual Coolant System
- Tailstock with Hydraulic Quill
- Centralized & Programmable Lubrication
- Laser Calibrated Axis for Highly Precise Positioning Accuracy and Repeatability
- Electricals with Quality Devices & Panel with Cooling System

PRODUCTIVITY IMPROVING OPTIONS

- Chip Conveyor
- Bar Feeder, Bar Puller & Part Catcher
- Programmable Tailstock
- Auto Door
- Automatic Tool Setting
- Live Quill (Built-in Revolving Center)
- Steady Rest
- Two Speed Gear Box for A₂6 Spindle
- Hydraulic Collet Chuck
- 12 Station Turret for DX 200/250 nvu
- Manual Guide-0i (Fanuc)
- Easy SMS System (Siemens)
- Shopturn (Siemens)
- Fully Toolled up Solution

JYOTI CNC AUTOMATION LTD.

jyoti.co.in

Regd.Works: Plot No.,G-506, Lodhika GIDC, Vill.-Metoda, Dist.-Rajkot - 360 021.

Gujarat (India) **T** +91-2827-235100-101 **F** +91-2827-235141

E info@jyoti.co.in, sales@jyoti.co.in

Download the
App



GET IT ON
Google Play

Download on the
App Store

Note: Specified information are subject to change arising out of continuous product improvement without notice. The description standard accessories/feature conforms to its list; not the photo of machine show in the catalogue. Other controller will have different configuration. Machine images are shown with option.



ISO 9001 : 2008