

HIGH-PRODUCTIVITY • ROBUSTNESS • PRECISION • TECHNOLOGY

VERTICAL MACHINING CENTERS

ROMI D SERIES

NEW GENERATION



www.romi.com





**MORE
PRODUCTIVITY
AND PROFITABILITY
FOR YOUR
BUSINESS!**

*In the constant transformation of industrial processes, it is crucial to have **differentials that make your products superior to those offered by competitors.***

*In this context, the insertion of new technologies in its production process, mainly by means of **modern, fast and precise machine tools, raises production performance.***

You get higher quality, productivity, efficiency and the best: higher profits than already achieved in your business!

With more than 90 years of history and global presence, we have preserved the values that have made our products recognized worldwide. **We offer the most cost-effective machine tools on the market.** Our commitment to the constant development of new solutions and dedication to innovation, results in robust, high technology and quality machine tools.

We guarantee full support at all stages of purchase through our sales and sales engineering teams, customer training, specialized technical assistance and spare parts. **Having a Romi machine tool assures that you have state of the art equipment** combined with a reputation of value, providing a high resale value in the future.

At Romi, you get a complete solution, much more than just equipment: **you have the security and tranquility of our full support at all times, always when you need it.** Ask us to find a suitable solution that your needs. **Our main goal is to make your business even more productive and profitable.**



Ultra Clean room



R & D



Flexible Manufacturing System (FMS)



Specialized technical assistance



Training



Spare parts

ROMI D SERIES

NEW GENERATION

High-productivity. Robustness. Precision. Tecnology.





ROMI D Series machines are extremely versatile for several machining applications. They are designed to operate in high production sites as well as in tool rooms. Our D Series machines offers high rigidity even under severe machining conditions and present thermal and geometric stability ensuring great performance, precision and productivity.



ROMI D 600

Headstock	10.000 rpm
Spindle Taper	ISO 40
Main Motor	25 hp / 18.5 kW
Aut. Tool Changer	20 tools
Table - mm (in)	914 x 560 (36 x 22)
CNC	Fanuc Oi-MF



ROMI D 800

Headstock	10.000 / 15.000 rpm
Spindle Taper	ISO 40
Main Motor	25 hp / 18.5 kW (10.000 rpm) 20 hp / 15.0 kW (15.000 rpm)
Aut. Tool Changer	30 tools
Table - mm (in)	914 x 560 (36 x 22)
CNC	Fanuc Oi-MF <i>i</i> -HMI



ROMI D 1000

Headstock	10.000 / 15.000 rpm
Spindle Taper	ISO 40
Main Motor	25 hp / 18.5 kW (10.000 rpm) 20 hp / 15.0 kW (15.000 rpm)
Aut. Tool Changer	30 tools
Table - mm (in)	1.220 x 560 (48 x 22)
CNC	Fanuc Oi-MF <i>i</i> -HMI



ROMI D 1250

Headstock	10.000 / 15.000 rpm
Spindle Taper	ISO 40
Main Motor	25 hp / 18.5 kW (10.000 rpm) 20 hp / 15.0 kW (15.000 rpm)
Aut. Tool Changer	30 tools
Table - mm (in)	1.320 x 560 (52 x 22)
CNC	Fanuc Oi-MF <i>i</i> -HMI



STRUCTURE

ROBUSTNESS AND TECHNOLOGY

Manufacturing process quality grants reliability and operational efficiency of ROMI machines. All machines are inspected with a laser system for positioning measurement and repeatability.

Axes alignment inspection is performed with a ballbar system ensuring perfect interpolation of X, Y and Z axis. ROMI D Series machines were designed with 3D CAD system and the entire structure was dimensioned by finite elements analysis software (FEA), resulting in superior structures for each machine size.



Linear guide benefits

- Feed rates up to 40 m/min (1,575 in/min)*
- Fast positioning of axes minimizing idle times and increasing productivity
- Allow high rates of acceleration
- Low lubrication oil consumption
 - Easy maintenance
 - High rigidity and long durability

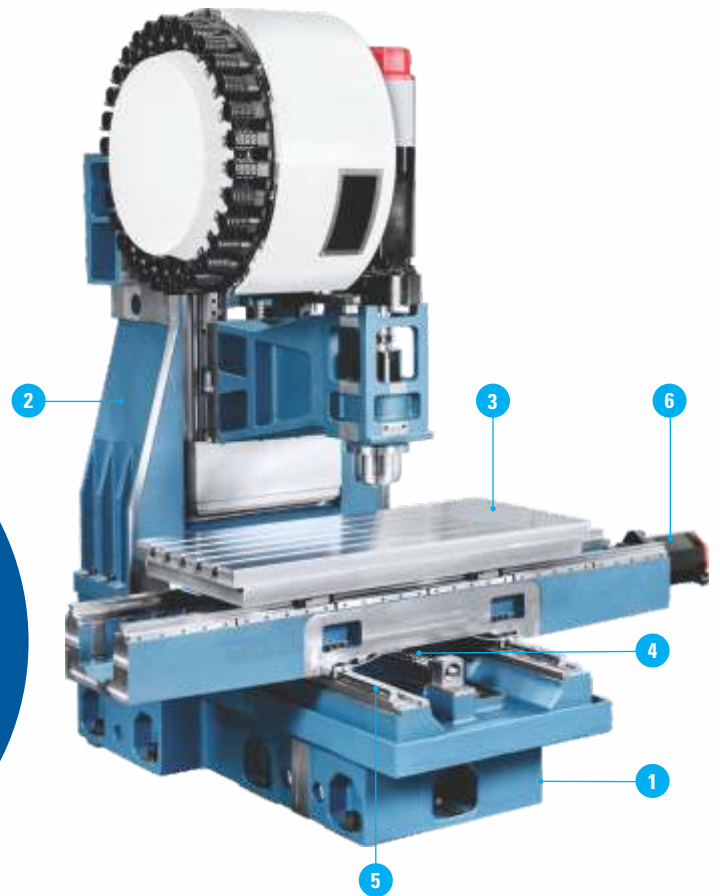

1

Monoblock **BASE** made of cast iron, designed to absorb vibrations, provides parts with excellent finishes, longer machine life and longer lasting cutting tools.

2

COLUMN: Dimensioned to support the headstock assembly with excellent geometric stability for the whole assembly.

3

The **TABLE** is supported on linear guides, with multiple T-slots for mounting and securing devices. Designed to support heavy parts with excellent stability.

4

BALLSCREWS: Hardened and ground with pre-loaded nuts provide high rigidity and high accuracy in both positioning and repeatability of axes.



5

LINEAR ROLLER GUIDES. Allows faster movements whilst ensuring precision and high accelerations due to low friction coefficient between the rails and blocks.

6

Brushless **AC SERVO MOTORS** are directly coupled to the ballscrews and have integrated absolute encoders, which transmit the movement directly, providing accurate positioning and excellent repeatability of axes.

(*) Except **ROMI D 600**



HEADSTOCK

HIGH PERFORMANCE AND PRECISION

Main motor is directly coupled to the headstock cartridge which offers great efficiency in the transmission of torque, power and rotation. Spindle taper is prepared for BT / BBT, offering great rigidity for tool holders.



A robust spindle cartridge with ultra precision bearings enables excellent accuracy and minimal temperature increases of the bearings even when operating continuously in high rpm's



CARTRIDGE prepared for cooling system (optional). For headstocks with 15,000 rpm, the cooling system is standard, contributing to the thermal and geometric stability of the assembly.

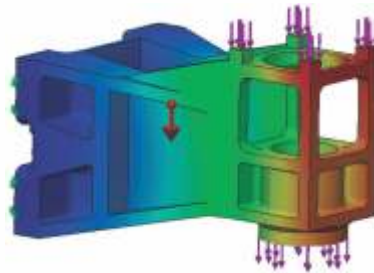

HEADSTOCK STRUCTURE that offers great thermal and geometric stability, rigidity and high capacity to absorb machining efforts without vibrations even the ones generated from heavy machining.



THERMAL COMPENSATION

Strategically placed on the machine, mathematical algorithms correct the position of the axes in real time. In this way, stable dimensional results are obtained, even for long periods of time.

Ultra precision angular contact **BALL BEARINGS** with permanent lubrication.

Bearing sealing by labyrinth.

PRESSURIZED SYSTEM - pneumatic seal: to prevent the bearings from contamination by cutting coolant and particles.

PNEUMATIC SYSTEM FOR SPINDLE TAPER CLEANING, preventing the entry of chips to avoid damage on tool shanks.

LINEAR ROLLER GUIDES. Allows faster movements whilst ensuring precision and high accelerations due to low friction coefficient between the rails and blocks.



AUTOMATIC TOOL CHANGER

EFFICIENCY AND PRODUCTIVITY



Fast, accurate, and reliable automatic tool changers, helping to increase productivity and machining efficiency. The automatic tool changer has 30 tools capacity (ROMI D 800 / D 1000 / D 1250) or 20 tools capacity (ROMI D 600).



Automatic Tool Changer with 20 tools capacity (ROMI D 600)



Automatic Tool Changer with 30 tools capacity (ROMI D 800 / D 1000 / D 1250)

Tool dimensions BT / CAT / DIN (*)

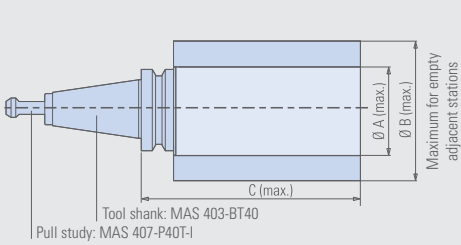

		ROMI D 600	ROMI D 800 / D 1000 / D 1250
Tipo		BT-40 / BBT-40	BT-40 / BBT-40
A	mm (in)	100 (3.9)	76 (3)
B	mm (in)	200 (7.9)	127 (5)
C	mm (in)	254 (10)	300 (11.9)
Max. weight	kg (lbs)	6 (13)	7 (15)
Max. weight total	kg (lbs)	65 (2.7)	150 (5.9)

(*) For machines with thru spindle coolant system, the tool shanks and pull studs must have a hole to pass the coolant thru spindle

For rotations over 10,000 rpm, it is recommended to use BBT mandrels. Regardless of rotation, all tools should be balanced in G2.5

CNC

TECHNOLOGY AND RELIABILITY



1. Environment that provides the visualization of various information on a single screen. Ex.: feed axes and main spindle load indicators, current program, modal codes, tool information, icons, alarms, etc.

Vertical Machining Centers from **ROMI D Series** are equipped with a FANUC Oi-MF Plus *i*-HMI CNC, which offers the user great facilities for programming with main screen with different areas for planning, machining, improvements and utilities, allowing access to functions in only two clicks. Ethernet interface, drive for Compact Flash card and USB port is standard.



2. Complete and dynamic tool manager, providing quick access to information.



3. Resources for corrective and preventive maintenance (messages, alarms, history, etc). Alert messages are sent before the fault even occurs, for efficient preventive maintenance.



4. The machining programs can be easily accessed and viewed in organized folders, with part figure, name and program number, making it easier to identify them.



5. Allows viewing of files in several formats, allowing the storage of manuals, diagrams and important information.



6. Several interactive machining cycles, such as: cavity cycles, drilling, threading, measurements, etc.



FANUC Oi-MF Plus with 10.4" screen (D 600) and FANUC Oi-MF Plus *i*-HMI with 15" touch screen (D 800, D 1000 and D 1250)



CHIPS TREATMENT

FULL REMOVAL OF MACHINING WASTE

The accentuated inclination of telescopic covers and chip trays favor the disposal of the chips, which are driven by the internal auger to the chip conveyor.



Chip conveyors (optionals)

Model	Types of chips	 Curled or long chips	 Short thin chips	Material			
				Steel	Aluminum	Non-ferrous metals (bronze and brass)	Cast iron
TCE (Longitudinal Hinged belt chip conveyor)		○	X	●	X	X	X
TCA (Longitudinal Drag belt chip conveyor)		X	●	○	○	○	○
TCL (Longitudinal light chip conveyor (floating chips))		○	○	●	●	○	X

● Fully indicated

○ Partly indicated

X Not indicated

TCA: chips smaller than 0.5 mm may contaminate the coolant tank and require frequent cleaning / chip clusters or chips larger than 50 mm may lock the conveyor

TCE: short chips smaller than 5 mm may contaminate the coolant tank and require frequent cleaning

TCL: chips smaller than 0.5 mm may contaminate the coolant tank and require frequent cleaning

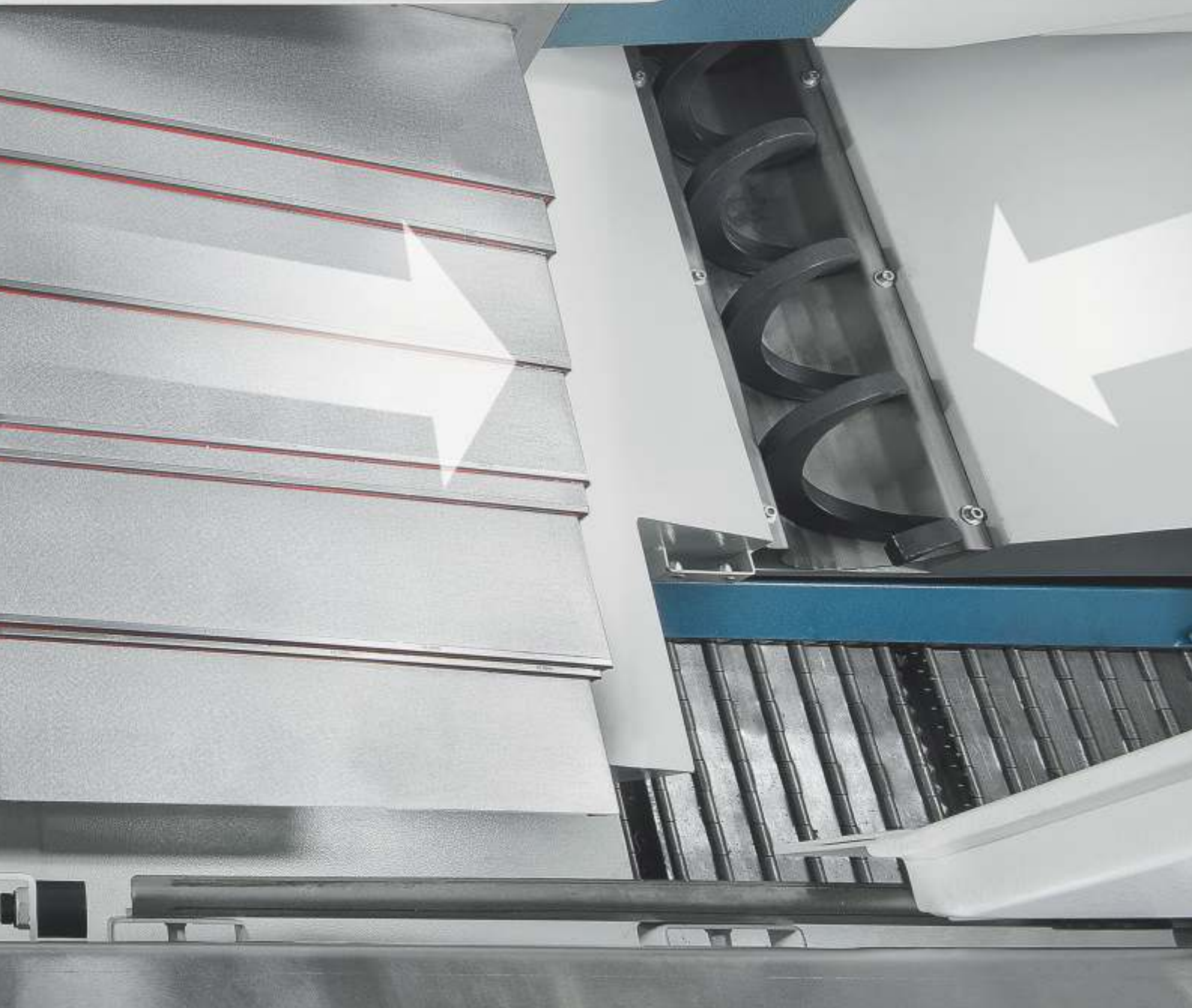

OPTIONALS

VERSATILITY FOR YOUR PRODUCTION

To adapt perfectly your Vertical Machining Centers from **ROMI D Series** to your machining needs, we offer a wide variety of optionals that can equip your machine and make it even more versatile.

1. Automatic Door and Safety Light Curtain
2. Status indicator light
3. Mist exhausting system
4. Wash Gun
5. Chip conveyor
6. Headstock cooling system (standard to 15,000 rpm and optional to 10,000 rpm)
7. Oil Skimmer



4TH AXIS ROTARY TABLE ROMI MGR



This optional allows the machining of parts at any angle and with continuous interpolation. It provides excellent positioning and repeatability. Its heavy duty construction and rigidity offers excellent vibration dampening. For machining of long parts it can be supplied with the optional tailstock.

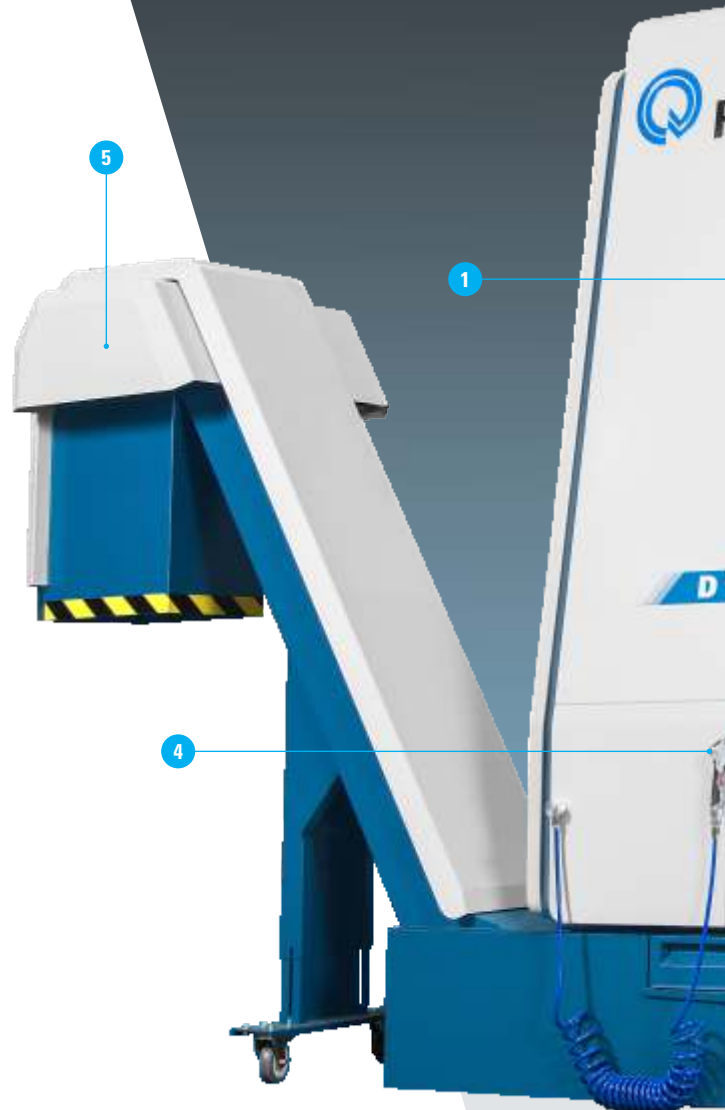



4. ROMI D-LINE HYBRID



Technical Specifications		ROMI D 600	ROMI D 800	ROMI D 1000	ROMI D 1250
Vertical headstock					
Spindle taper	ISO	40	40	40	40
Speed range (version 10.000 rpm)	rpm	10 to 10.000	10 to 10.000	10 to 10.000	10 to 10.000
Speed range (version 15.000 rpm)	rpm	-	15 to 15.000	15 to 15.000	15 to 15.000
Feeds					
Rapid traverse (X / Y / Z axes)	m/min (ipm)	30 (1,181)	40 (1,575)	40 (1,575)	40 (1,575)
Max. programmable cutting feed	m/min (ipm)	20 (787)	20 (787)	20 (787)	20 (787)
Travels					
Superior table travel (X axis)	mm (in)	600 (23.6)	800 (31.5)	1,020 (40)	1,270 (50)
Inferior table travel (Y axis)	mm (in)	610 (24)	610 (24)	610 (24)	610 (24)
Headstock travel (Z axis)	mm (in)	640 (25)	640 (25)	640 (25)	640 (25)
Distance from spindle nose to table	mm (in)	110 to 750 (4.3 to 30)	110 to 750 (4.3 to 30)	110 to 750 (4.3 to 30)	110 to 750 (4.3 to 30)
Table					
Surface	mm (in)	914 x 560 (36 x 22)	914 x 560 (36 x 22)	1,220 x 560 (48 x 22)	1,320 x 560 (52 x 22)
T-slot width x distance	mm (in)	18 x 89 (0.71 x 3.5)	18 x 89 (0.71 x 3.5)	18 x 89 (0.71 x 3.5)	18 x 89 (0.71 x 3.5)
Number of T-slots	un	5	5	5	5
Max. Weight on table (uniformly distributed)	kg (lbs)	800 (1,800)	900 (2,000)	1,000 (2,205)	1,400 (3,000)
Automatic Tool Changer					
Type		carousel	automatic arm	automatic arm	automatic arm
Tools capacity	un	20	30	30	30
Max. tool diameter	mm (in)	100 (3.9)	76 (3)	76 (3)	76 (3)
Max. tool diameter when adjacent stations are empty	mm (in)	200 (7.9)	127 (5)	127 (5)	127 (5)
Max. tool length	mm (in)	254 (10)	300 (11.9)	300 (11.9)	300 (11.9)
Tool holder type	type	BT / CAT / DIN	BT / CAT / DIN	BT / CAT / DIN	BT / CAT / DIN
Max. tool weight	kg (lbs)	6 (13)	7 (15)	7 (15)	7 (15)
Max. tool weight on ATC	kg (lbs)	65 (2.7)	150 (5.9)	150 (5.9)	150 (5.9)
Tool change time (tool to tool)	s	4,6	3,2	3,2	3,2
CNC					
Model		Fanuc Oi-MF Plus	Fanuc Oi-MF Plus i-HMI	Fanuc Oi-MF Plus i-HMI	Fanuc Oi-MF Plus i-HMI
Installed power (10.000 rpm)					
AC main motor	hp (kW)	25 / 18,5	25 / 18,5	25 / 18,5	25 / 18,5
Total installed power	kVA	30	35	35	35
Installed power (15.000 rpm)					
AC main motor	hp (kW)	-	20 / 15	20 / 15	20 / 15
Total installed power	kVA	-	40	40	40
Dimension and weight (approx.)					
Height**	mm (in)	3,140 (124)	3,140 (124)	3,140 (124)	3,140 (124)
Area (front x side)*	mm (in)	2,495 x 2,425 (98 x 95)	3,170 x 2,535 (125 x 100)	3,390 x 2,535 (133 x 100)	3,700 x 2,535 (146 x 100)
Machine net weight	kg (lbs)	6.000 (13,200)	6,600 (14,500)	6,900 (15,200)	7,000 (15,400)
Net weight (machine + optionals + piece)	kg (lbs)	9,300 (20,500)	9,700 (21,400)	9,900 (21,800)	10.400 (23,000)

(*) Without chip conveyor (**) Without mist exhausting system (optional)



Standard equipment

- Headstock with BT/ BBT-40 interface (spindle taper ISO-40)
- Rapid traverse 30,000mm/min - X, Y and Z axis (ROMI D 600)
- Rapid traverse 40,000mm/min - X, Y and Z axis (ROMI D 800 / D 1000 / D 1250)
- CNC Fanuc Oi-MF Plus with 10.4" LCD color screen (ROMI D 600)
- CNC Fanuc Oi-MF Plus with 15" LCD color touchscreen with new HMI (ROMI D 800 / D 1000 / D 1250)
- Fully enclosed splash guard
- Thermal compensation
- Complete documentation for ROMI product in electronic media
- Speed range from 10 to 10,000 rpm, maximum torque - 118 Nm
- Speed range from 15 to 15,000 rpm, maximum torque - 102 Nm (available ROMI D 800 / D 1000 / D 1250)
- Linear roller guides for X, Y and Z axis
- Electrical installation available for the following voltage/frequencies: 400VCA/50-60Hz
- Ethernet Interface
- Main set of wrenches for machine operation
- Set of levelling screws and nuts
- Sealed worklight
- 25hp / 18,5kW (regime S3-15%) Fanuc AC main motor for 10 to 10,000rpm
- 20hp / 15kW (S1 continuous regime) for 15 to 15,000rpm - available to ROMI D 800 / D 1000 / D 1250)
- Manual auxiliary panel, with JOG and handwheel functions for the both axis
- Electric panel with centrifugal climatization and positive pressure
- Interlocked sliding safety simple door (ROMI D 600)
- Interlocked sliding safety double door (ROMI D 800 / D 1000 / D 1250)
- Headstock coolant system with temperature control for 15 a 15,000rpm version (available to ROMI D 800 / D 1000 / D 1250)
- Automatic lubrication system with line filter and oil level sensor, for the guides and ball screw
- Cutting cooling system with coolant pump (5bar) (coolant tank not included)
- Pneumatic system for cleaning the spindle taper and tool unlocking
- 20 tools umbrella-type automatic tool changer (ROMI D 600)
- 30 tools automatic tool changer (ROMI D 800 / D 1000 / D 1250)
- Standard colors: Texturized Epoxy Enamel Munsell Blue 10B-3/4 and Texturized Epoxy Gray RAL 7035.

Optional equipment

- Non-articulated horizontal control panel adaptation (ROMI D 800 / D 1000 / D 1250)
 - Air conditioning for electric cabinet
 - Autotransformer - 200 to 250VCA or 360 to 480VCA
 - Box for chips collecting (coolant tank) 400 liters capacity (A)
 - Auto power off
 - Magnetic Filter (G)
 - Filter for smoke - generated from the heating of the coolant oil during machining process (C)
 - 6 M codes for external automation interface - 3 independents outputs: 3 Ms Code Enable and 3 Ms Code Disable
 - Eletrical wiring interface - preset of tools and Measure and inspection of parts
 - Electronic interface
 - Remote diagnostics interface via cable
 - Rotary table interface (B)
 - Preset of tools and measure and inspection of parts interface (F)
 - Status light indicator (3 colors)
 - Rotary table MGR 230 or MGR 400 (available to D 1000 and D 1250) (D)
 - MT-3 center for rotary table
 - Manual or Pneumatic tailstock for rotary table
 - Universal chuck and adapter plate for MGR
 - Wash gun
 - Automatic door electronic sensor security system
 - Oil skimmer
 - Mist exhausting system
 - Pneumatic chip cleaning system during machining process
 - Cleaning system the machining area, for machine equipped with chip conveyor (H)
 - Preset of tools OTS sensor (E)
 - Headstock coolant system with temperature control
 - High pressure pump for thru spindle coolant system (7 bar or 15 bar)
 - High pressure pump for thru spindle coolant system (20 bar or 70 bar)
 - Measure and inspection of parts system with OMP-60 probe, optical sensor, with tip: PS3-1C (E)
 - Linear scale for X, Y and Z axis
 - Longitudinal Hinged belt chip conveyor (TCE) and coolant tank 600 liters capacity (A)
 - Longitudinal light chip conveyor (TCL), coolant tank 600 liters capacity (A)
 - CAT 40 or DIN 40 Automatic Tool Changer (in place of standard)
 - Longitudinal Drag belt chip conveyor (TCA) and coolant tank 600 liters capacity (A)
- (A)** Configurable Optional Equipment Mandatory to select
(B) This interface is applied to the rotary table manufactured according to Romi's specification.
(C) Mandatory "Mist exhausting system" (optional)
(D) Mandatory "Rotary table interface" (optional)
(E) Mandatory "Preset of tools and measure and inspection of parts interface" (optional)
(F) Mandatory "Eletrical wiring interface - preset of tools and Measure and inspection of parts" (optional)
(G) Only applied to machine equipped with "chip conveyor"
(H) Recommended the sale for aluminium machining.

Machine dimensions - dimensions in mm (in)

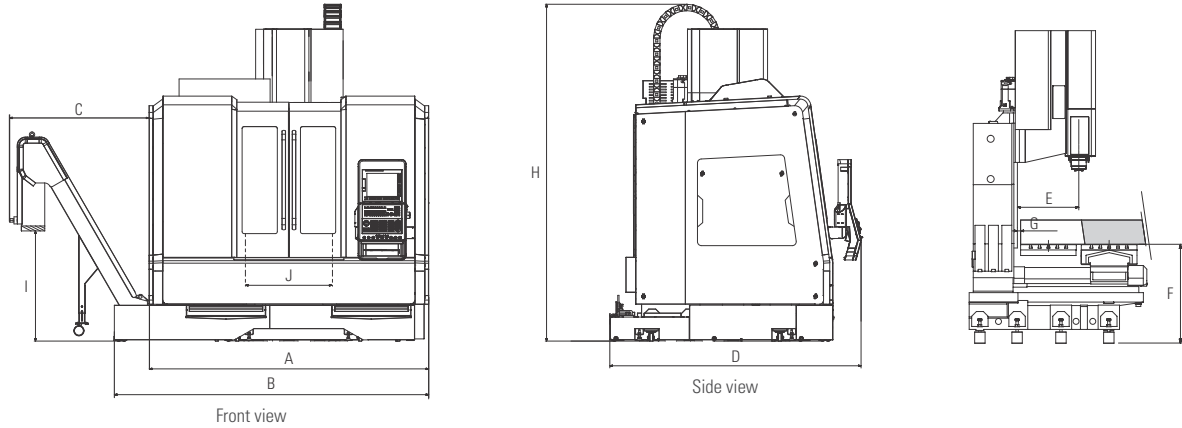

		A	B	C			D	E	F**	G	H*** máx	H mín	I	J
				TCA	TCE	TCL								
ROMI D 600	mm (in)	2,495* (98)	3,080 (121)	1.650 (65)	1.910 (75,2)	1.890 (74,5)	2,425 (95)	617 (24)	990 (39)	32 (1.26)	3,140 (124)	2,810 (111)	1,110 (44)	790 (31)
ROMI D 800	mm (in)	2,820 (111)	3,170* (125)	1.410 (55,5)	1.670 (66)	1.650 (65)	2,535 (100)	617 (24)	990 (39)	32 (1.26)	3,140 (124)	2,810 (111)	1,110 (44)	820 (32.3)
ROMI D 1000	mm (in)	3,040 (120)	3,390* (133)	1.410 (55,5)	1.670 (66)	1.650 (65)	2,535 (100)	617 (24)	990 (39)	32 (1.26)	3,140 (124)	2,810 (111)	1,110 (44)	1,040 (41)
ROMI D 1250	mm (in)	3,350 (132)	3,700* (146)	1.410 (55,5)	1.670 (66)	1.650 (65)	2,535 (100)	617 (24)	990 (39)	32 (1.26)	3,140 (124)	2,810 (111)	1,110 (44)	1,340 (52.75)

(*) Values for machines equipped with chip trays only

(**) It may vary according to the type and quality of the ground

(***) Without mist exhausting system (optional)

Power graphs

10.000 rpm Headstock

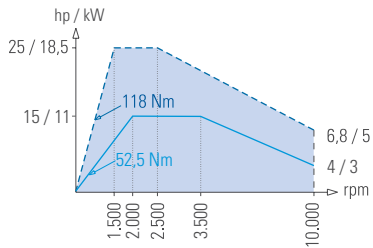

■ Continuous regime S1 ▨ Intermittent regime S3 - 15%

15.000 rpm Headstock - Continuous rating S1

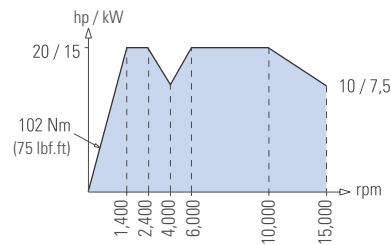

Drawings are note in scale.

Table dimensions - dimensions in mm (in)

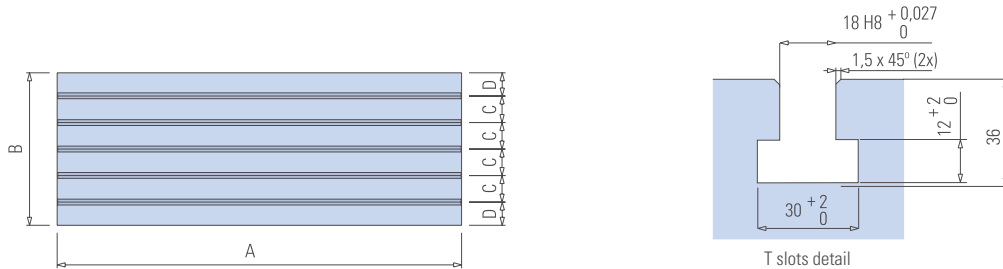

		A	B	C	D
ROMI D 600 / D 800	mm (in)	914 (36)	560 (22)	89 (3.5)	102 (4)
ROMI D 1000	mm (in)	1,220 (48)	560 (22)	89 (3.5)	102 (4)
ROMI D 1250	mm (in)	1,320 (52)	560 (22)	89 (3.5)	102 (4)



Work area layout - dimensions in mm (in)

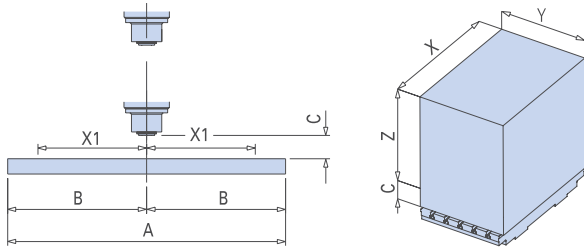

		A	B	C	X	X1	Y	Z
ROMI D 600	mm	914	457	110	600	300	610	640
	(in)	(36)	(18)	(4.3)	(24)	(11.8)	(24)	(25)
ROMI D 800	mm	914	457	110	800	400	610	640
	(in)	(36)	(18)	(4.3)	(31)	(15.7)	(24)	(25)
ROMI D 1000	mm	1,220	610	110	1,020	510	610	640
	(in)	(48)	(24)	(4.3)	(40)	(20)	(24)	(25)
ROMI D 1250	mm	1,320	660	110	1,270	635	610	640
	(in)	(52)	(26)	(4.3)	(50)	(25)	(24)	(25)

Internal space - dimensions in mm (in)

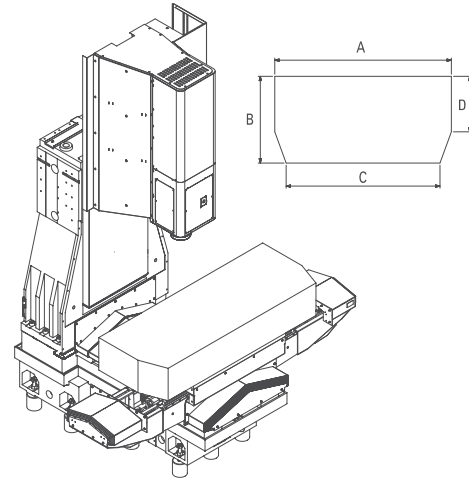

		A	B	C	D
ROMI D 600	mm	1,300	610	-	-
	(in)	(51.2)	(24)	-	-
ROMI D 800	mm	1,630	610	1,470	390
	(in)	(64.2)	(24)	(58)	(15.4)
ROMI D 1000	mm	1,750	610	1,590	390
	(in)	(69)	(24)	(63)	(15.4)
ROMI D 1250	mm	1,935	610	1,775	390
	(in)	(76.2)	(24)	(70)	(15.4)

4th Axis Rotary Table - ROMI MGR



Side view

	MGR 230	MGR 400
 N (lbf)	11,000 (2,472.9)	23,000 (5,170.6)
 N.m (f x L) (lbf.ft) (f x L)	850 (626.9)	2,500 (1,844)
 N.m (f x R) (lbf.ft) (f x R)	480 (354) (hydropneumatic brake)	1,500 (1,106.3)

Face		MGR 230	MGR 400
Height from table to center	mm (in)	170 (6.7)	250 (9.8)
Center hole diameter	mm (in)	50 (2.0)	81 (3.2)
Face diameter	mm (in)	230 (9.1)	400 (15.7)
T-slot width	mm (in)	12 (0.47)	14 (0.55)
Number of T-slots		4	4
Work position		horizontal	horizontal
Capacities			
Max. load capacity (on chuck only)	kg (lbs)	175 (390)	250 (550)
Available torque - Fanuc servo motor	N.m (lbf.ft)	500 (368.8)	1,000 (737.6)
Maximum speed - Fanuc servo motor	rpm	17	11
Accuracy (A)			
Positioning	s	+/- 15	+/- 15
Repeatability	s	+/- 10	+/- 10
Hydropneumatic braking system			
Work pressure	bar (kgf/cm ²) (psi)	6 (6) (87)	6 (6) (87)
Brake locking torque	N.m (lbf.ft)	480 (354)	1,500 (1,106.3)
Dimensions and weight			
Height	mm (in)	285 (11.2)	460 (18.1)
Area	mm (in)	487 x 410 (19.2 x 16.1)	480 x 470 (18.9 x 18.5)
Total weight with motor (approx.)	kg (lbs)	92 (203)	300 (661)

(A) Results obtained with a new MGR, properly installed in a controlled temperature facility, at 22°C (+/- 1°C)

**CNC FANUC Oi-MF Plus i-HMI
ROMI D 800 / D 1000 / D 1250**



1 - Resources and CNC Performance:

- . Display touchscreen LCD 15"
- . Qwerty keyboard
- . Operation Panel
- . Look Ahead = 200
- . Minimum Increment Positioning 0.001 mm or 0.0001 inches
- . Simultaneous control of up to 4 axes
- . Stroke Limit Check Before Move
- . Linear Interpolation
- . Circular Interpolation
- . Helical Interpolation
- . Protection Key
- . PCMCIA Interface - 16 GB Limit
- . Ethernet Interface
- . USB Interface
- . Data automatic backup
- . Auxiliary functions (T, S, M, F)
- . Parts counter
- . Clock
- . Calculator
- . Machining Cycle Time
- . Pitch Error Compensation
- . Bell-Shaped Accel./Decel. in Rapid Feed
- . Linear acceleration/deceleration after interpolation for rapid traverse
- . Rapid Traverse Block Overlap
- . Power Mate Manager
- . Machine Lock
- . Software limit
- . Interlocking
- . Backlash Compensation
- . Torque Limit Skip
- . Languages: Portuguese, English, German, French, Italian, Spanish
- . Energy Saving Level Selecting Function
- . Stylus Plastic Pen

2 - Programming Resources:

- . Floating Tapping
- . Programmable Return to Reference Position of machine (G28, G30 e G53)
- . High Speed and high quality Machining Package
- . Programming Error Prevention

3 - Feedrate Functions:

- . Feed per Minute
- . Feed per Rotation
- . Dwell (G04)

4 - Graphic Functions:

- . Graphic Display
- . Graphic Simulation - 2D
- . Graphic Simulation - 3D
- . Residual Material Removal

5 - Coordinate Systems:

- . Local Coordinate System Setting
- . Machine Coordinate System Selection (G53)
- . Workpiece Coordinate System
- . Workpiece Coordinate Preset (G92, G92.1)
- . Tool Geometry and Wear Compensation = 100

6 - Coordinate Values and Dimensions:

- . Absolute (G90) or Incremental (G91) Programming Mode
- . Inch/Metric Conversion (G20, G21)
- . Coordinate System Rotation
- . Transfer Zero Point
- . Programmable Mirror Image
- . Programmable Data Input

7 - Spindle Functions:

- . Spindle Speed Function
- . Spindle Orientation (M19)
- . Monitoring of current Spindle Speed

8 - Applied Tool Function:

- . Tool Radius Compensation
- . Input Relative Corrector Tool
- . Tool Life Management
- . Tool length measuring Screen – Manual Mode i-HMI

9 - Macro:

- . Macro B
- . Addition of Custom Macro Common Variable
- . Macro Executor
- . Mbytes of memory for application in "Macro Executor" and "Fanuc Picture" = 6MB
- . Ladder programming

10 - Simplification Program Functions:

- . End Face Peck Drilling Cycle
- . Direct Drawing Dimension
- . Drilling / Boring
- . Rigid Tapping
- . Retraction for Rigid Tapping
- . Cylindrical Interpolation
- . Polar Coordinate Command
- . Engraving cycle

11 - Programming Format:

- . Programming Format Command ISO Fanuc-10/11
- . i-HMI CNC-Programming

12 - Execution Operations:

- . Number / program search
- . Comments
- . Sub-program Call
- . MDI Operation
- . Cycle Start
- . Single Block
- . Stop Program Execution
- . Optional Stop
- . Block Delete (" / ")
- . Program Restart
- . DNC Function
- . Program Test Function
- . Dry Run Function
- . Machine Home
- . High Speed Skip
- . Spindle Override Switch
- . Tool retract and recover
- . G-Codes System A/B/C
- . Sequence Number Search
- . Extended Part Program Editing
- . Background Editing
- . Registerable Part Programs = 1000
- . Part Program Storage Size = 2 Mbytes (5120m)
- . Manual handle Feed
- . JOG Feed
- . Feed Override Switch

13 - Maintenance Functions:

- . Course Limits
- . Emergency Stop
- . External Message Ladder
- . Alarm History
- . Operating History
- . Maintenance
- . Analysis of the servo system
- . Help Function
- . Diagnosis Screen
- . Maintenance Screen
- . Power consumption monitoring

OPTIONALS

- . 4Gb/16 Gb PCMCIA card
- . RS-232 Serial Interface (2 channels)
- . Anti-Reflective Protection Membrane
- . Linear Scale X/Z/Y axes
- . Ethernet Data Server Interface
- . Energy consumption monitoring



CNC FANUC Oi-MF - ROMI D 600



1 - Resources and CNC Performance:

- . Display LCD 10,4"
- . Qwerty keyboard
- . Operation Panel
- . Look Ahead = 200
- . Minimum Increment Positioning 0.001mm or 0.0001 inches
- . Simultaneous control of up to 4 axes
- . Stroke Limit Check Before Move
- . Linear Interpolation
- . Circular Interpolation
- . Helical Interpolation
- . Protection Key
- . PCMCIA Interface - 16 GB Limit
- . Ethernet Interface
- . USB Interface
- . Data automatic backup
- . Auxiliary functions (T, S, M, F)
- . Parts counter
- . Clock
- . Calculator
- . Machining Cycle Time
- . Pitch Error Compensation
- . Bell-Shaped Accel./Decel. in Rapid Feed
- . Linear acceleration/deceleration after interpolation for rapid traverse
- . Rapid Traverse Block Overlap
- . Power Mate Manager
- . Machine Lock
- . Software limit
- . Interlocking
- . Backlash Compensation
- . Torque Limit Skip
- . Languages: Portuguese, English, German, French, Italian, Spanish
- . Energy Saving Level Selecting Function

2 - Programming Resources:

- . Floating Tapping
- . Programmable Return to Reference Position of machine (G28, G30 e G53)
- . High Speed and High Quality Machining Package
- . Programming Error Prevention

3 - Feedrate Functions:

- . Feed per Minute
- . Feed per Rotation
- . Dwell (G04)

4 - Graphic Functions:

- . Graphic Display ISO/2D/3D

5 - Coordinate Systems:

- . Local Coordinate System Setting
- . Machine Coordinate System Selection (G53)
- . Workpiece Coordinate System
- . Workpiece Coordinate Preset (G92, G92.1)
- . Tool Geometry and Wear Compensation = 100
- . Absolute (G90) or Incremental (G91) Programming Mode
- . Inch/Metric Conversion (G20, G21)

6 - Coordinate Values and Dimensions:

- . Coordinate System Rotation
- . Transfer Zero Point
- . Programmable Mirror Image
- . Programmable Data Input

7 - Spindle Functions:

- . Spindle Speed Function
- . Spindle Orientation (M19)
- . Monitoring of current Spindle Speed

8 - Applied Tool Function:

- . Tool Radius Compensation
- . Input Relative Corrector Tool
- . Tool Life Management
- . Tool length measuring Screen – Manual Mode

9 - Macro:

- . Macro B
- . Addition of Custom Macro Common Variable
- . Macro Executor
- . Mbytes of memory for application in "Macro Executor" and "Fanuc Picture" = 6MB
- . Ladder programming

10 - Simplification Program Functions:

- . End Face Peck Drilling Cycle
- . Direct Drawing Dimension
- . Drilling / Boring
- . Rigid Tapping
- . Retraction for Rigid Tapping
- . Cylindrical Interpolation
- . Polar Coordinate Command

11 - Programming Format:

- . Programming Format Command ISO Fanuc-10/11

12 - Execution Operations:

- . Number / program search
- . Comments
- . Sub-program Call
- . MDI Operation
- . Cycle Start
- . Single Block
- . Stop Program Execution
- . Optional Stop
- . Block Delete (" / ")
- . Program Restart
- . DNC Function
- . Program Test Function
- . Dry Run Function
- . Machine Home
- . High Speed Skip
- . Spindle Override Switch
- . Tool retract and recover
- . G-Codes System A/B/C
- . Sequence Number Search
- . Extended Part Program Editing
- . Background Editing
- . Registerable Part Programs = 400
- . Part Program Storage Size = 2 Mbytes (5120m)
- . Manual handle Feed
- . JOG Feed
- . Feed Override Switch

13 - Maintenance Functions:

- . Course Limits
- . Emergency Stop
- . External Message Ladder
- . Alarm History
- . Operating History
- . Maintenance
- . Analysis of the servo system
- . Help Function
- . Diagnosis Screen
- . Maintenance Screen
- . Power consumption monitoring

OPTIONALS

- . Manual Guide i
- . Number of Registered programs, expansion (1000)
- . Ethernet Data Server Interface
- . 4Gb/16 Gb PCMCIA card
- . RS-232 Serial Interface (2 channels)
- . Linear Scale X/Z/Y axes
- . Energy consumption monitoring

WORLDWIDE PRESENCE

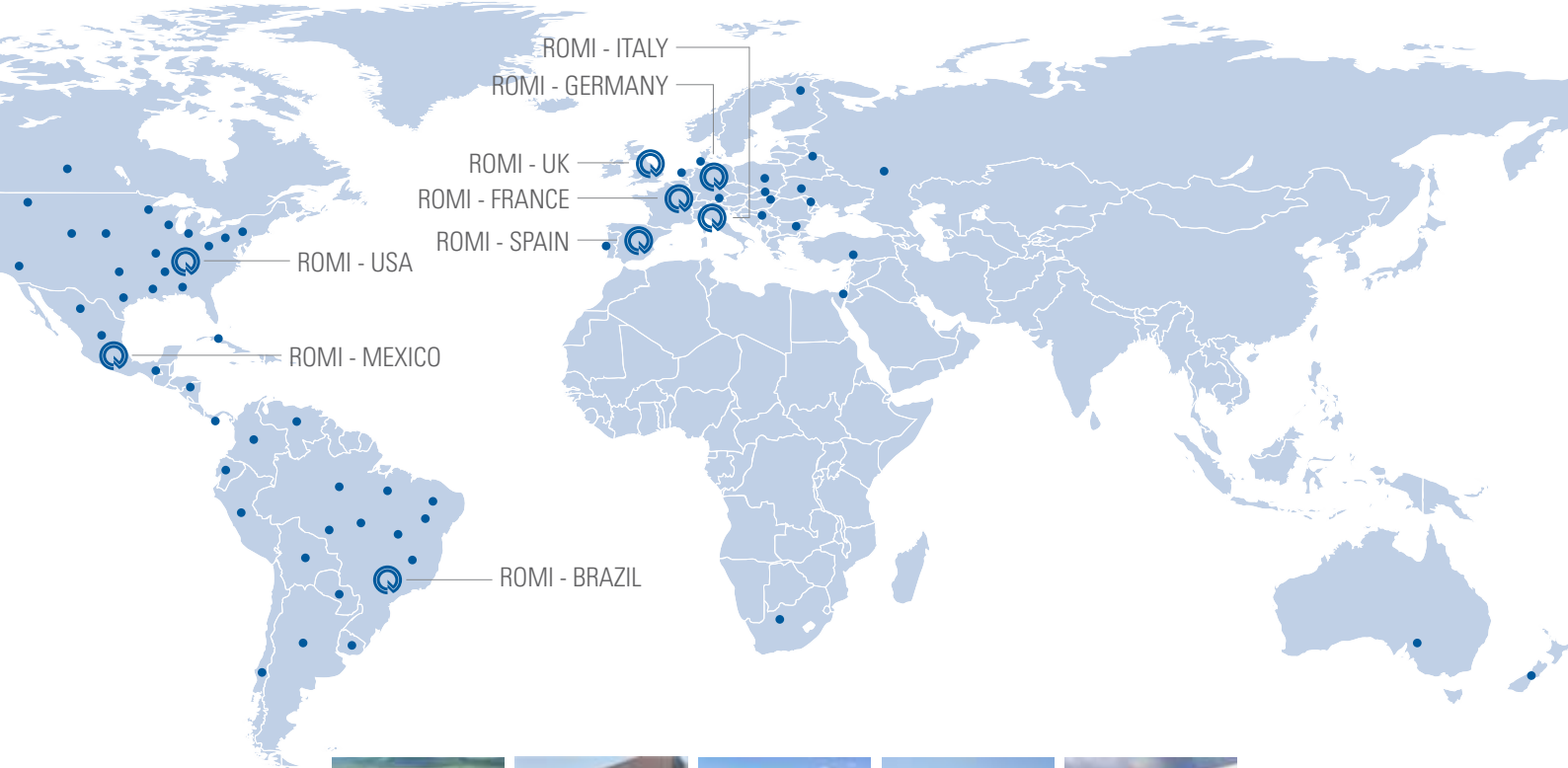

ROMI

WWW.ROMI.COM

Indústrias Romi SA
Rod. SP 304, Km 141,5
Santa Bárbara d'Oeste SP
13459 057 Brazil
+55 (19) 3455 9000

América Latina
+55 (19) 3455 9800
export-mf@romi.com

**Burkhardt+Weber
Fertigungssysteme GmbH**
Burkhardt+Weber-Strasse 57
72760 Reutlingen, Germany
+49 7121 315-0
info@burkhardt-weber.de
www.burkhardt-weber.de

ROMI Machine Tools, Ltd
1845 Airport Exchange Blvd
Erlanger KY - 41018 USA
+1 (859) 647 7566
sales@romiusa.com
www.romiusa.com

ROMI Europa GmbH
Burkhardt+Weber-Strasse 57
72760 Reutlingen, Germany
+49 7121 315-604
sales@romi-europa.de
www.romi-europa.de

ROMI France SAS
Parc de Genève, 240
Rue Ferdinand Perrier 69800
ST Priest
+33 4 37 25 60 70
infos@romifrance.fr
www.romifrance.fr

ROMI Machines UK Limited
Leigh Road
Swift Valley Industrial Estate
Rugby CV21 1DS
+44 1788 544221
sales@romiuk.com
www.romiuk.com

ROMI Máquinas España
C/ Telemática, 9 - Polígono
Industrial La Ferreria - 08110
Montcada i Reixac - Barcelona
+34 93 719 4926
info@romi.es
www.romi.es

ROMI en México
Condominio Parque Arista, Calle
Gral. Mariano Arista 54, bodega 19
Col. Argentina Poniente, Miguel Hidalgo
C.O. 11230, CDMX, México
+521 55 9154 5851
ventasmx@romi.com
www.romimexico.com

ROMI Italia Srl
Via Morigi, 33 - 29020
Gossolengo (PC) - Italia
+39 0523 778 956
commerciale@romiitalia.it
www.romiitalia.it



ISO 9001:2015
Certificate No. 31120



ISO 14001:2015
Certificate No. 70671

**CE safety regulation compliance available only for the European Community or under request.
Check availability and technical characteristics of the products to your country.**